

## **200A, 25 kV Class Loadbreak Protective (Insulating) Cap**



## APPLICATION

The Chardon Protective Cap is an accessory product to other 25 kV, 200A products with loadbreak interfaces (bushing inserts, loadbreak junctions, feed thru inserts, etc.). It is designed to physically seal and electrically insulate loadbreak bushing interfaces. When installed on a loadbreak bushing interface, and

properly grounded using the attached drain wire, the Loadbreak Protective Cap provides a submersible, fully shielded insulated cap for energized bushings.

The Loadbreak Protective Cap can be used for temporary or permanent applications.

## PRODUCTION TESTS

Tests conducted in accordance with IEEE/ANSI Standard 386.

- / Minimum Corona Voltage Level – 19 kV
- / AC 1 Minute Withstand – 40 kV

Tests conducted in accordance with Chardon manufacturing process requirements:

- / Physical Inspection
- / Periodic Dissection
- / Periodic X-ray Analysis

## VOLTAGE RATINGS

<b>Voltage Class</b>	25 kV
<b>Max. Rating Phase to Phase</b>	26.3 kV
<b>Max. Rating Phase to Ground</b>	15.2 kV
<b>AC 1 Minute Withstand</b>	40 kV
<b>DC 15 Minute Withstand</b>	78 kV
<b>BIL and Full Wave Crest</b>	125 kV
<b>Minimum Corona Voltage Level</b>	19 kV

• 25LIC200-122518-REV01

## DETAILED COMPOSITION OF THE CHARDON LOADBREAK PROTECTIVE CAP

### / DRAIN WIRE TAB

Drain wire tabs provide a convenient point to connect drain wire to ensure grounding of the connector shield.

### / SEMICONDUCTING INSERT

Precision molded peroxide cured semiconducting insert provides corona-free electrostatic shielding of the connector.

### / LATCHING RING

Semiconducting molded locking ring secures cap on nose piece of mating product.

### / INSULATION LAYER

High quality peroxide cured EPDM Insulation is mixed and formulated in-house for complete control of rubber characteristics.

### / PULLING EYE

Molded in stainless steel pulling eye insures high strength for hotstick operation.

### / SEMICONDUCTING SHIELD

Precision molded peroxide cured conducting shield provides ground shield continuity.

### / PROBE

Brass probe provides reliable conductive path with mating female contacts.

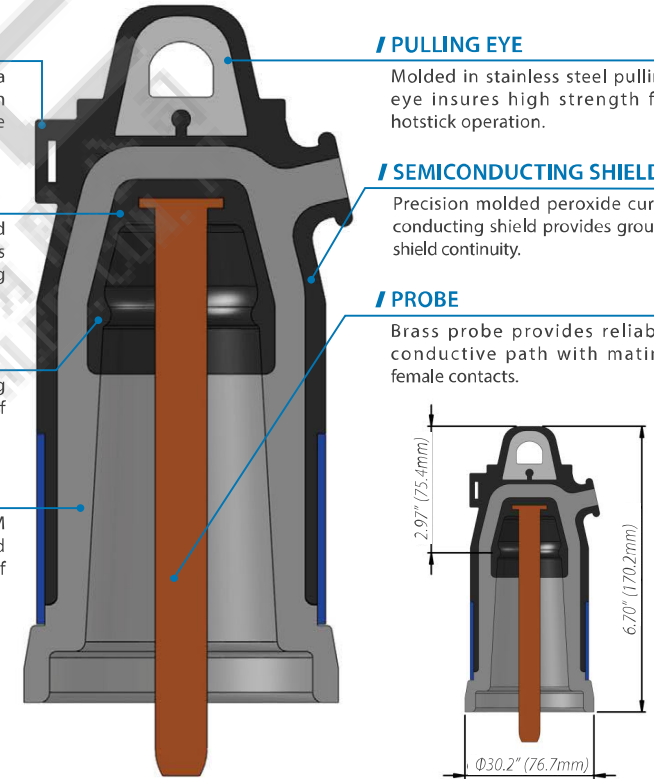

## ORDERING INFORMATION

25 kV, 200A Loadbreak Protective Cap

25-LIC200