

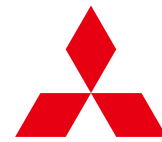

for a greener tomorrow



**mitsubishi
ELECTRIC**

Changes for the Better

FACTORY AUTOMATION

ELECTRONIC MULTI-MEASURING INSTRUMENT ME96SS



SS Ver.B
Super-S Series

ME96 Super-S Series Electronic Indicating Instruments functions and optional units

Highly appreciated ME96SS Series Electronic Multi-Measuring Instruments measuring functions and network capability has been released.

① ME96SSH-B-MB (high-performance model)

Major features

- [1] Supports highly accurate measurement (accuracy of current/voltage: 0.1%, active energy: class 0.5S) and high-order harmonic measurement (1st to 31st).
- [2] Incorrect wiring determination support function
- [3] Wide viewing angle LCD
- [4] Built-in logging function
- [5] Display 4 items at the same time

② ME96SSRB-MB (standard model)

Major features

- [1] Incorrect wiring determination support function
- [2] Wide viewing angle LCD
- [3] Built-in logging function
- [4] Display 4 items at the same time

③ ME96SSEB-MB (economy model)

Major features

- [1] Compact size
- [2] Incorrect wiring determination support function
- [3] Display 4 items at the same time

with enhanced measuring

have been remodeled, and ME96 Super-S Series  with enhanced.

④ Optional plug-in modules

Major features

- [1] MODBUS TCP communication unit
- [2] Data logging unit
- [3] CC-Link communication unit
- [4] Digital input and output unit
- [5] Analog, pulse and alarm output unit

Remarks

MODBUS RTU communication function provided as standard

Contents

■ Outline and Features	3
■ ME96 Super-S Series Ver.B Features	4
■ Specifications	9
■ Operating Instructions	14
■ External Dimensions, Installation and Connections	29
■ Related Products	33
■ Safety Precautions	35

Outline and Features

Compact size

- Realized downsizing for ME96SSEB-MB.

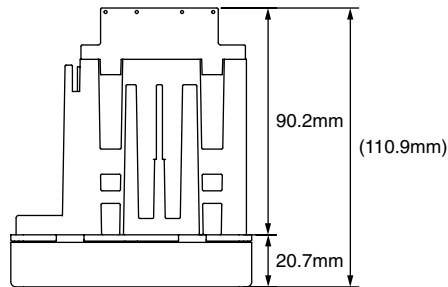

ME96SSEA-MB
(Conventional type)

It contributes to space saving!

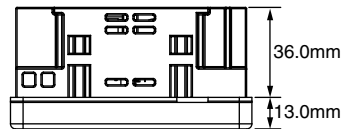

ME96SSEB-MB
(New type)

Improved Measurement Functions

- Added measurement function, reactive energy, apparent energy, reactive power and apparent power for ME96SSEB-MB.



Model name	Transmission/Option specifications	Main measurement items
ME96SSHB-MB (High-performance model)	MODBUS RTU communication Plug-in module (options) <ul style="list-style-type: none"> Analog/Pulse/Contact output/input CC-Link communication Digital input/output (for MODBUS RTU communication) Backup (on SD card) MODBUS TCP communication 	A, DA, V, Hz = $\pm 0.1\%$ W, var, VA, PF = $\pm 0.2\%$ VAh = $\pm 2.0\%$ Wh = class 0.5S (IEC62053-22) varh = class 1S (IEC62053-24) Harmonics = 31 st -deg (max) Rolling demand = W, var, VA
ME96SSRB-MB (Standard model)	MODBUS RTU communication Plug-in module (options) <ul style="list-style-type: none"> Analog/Pulse/Contact output/input CC-Link communication Digital input/output (for MODBUS RTU communication) Backup (on SD card) MODBUS TCP communication 	A, DA, V = $\pm 0.2\%$ Hz = $\pm 0.1\%$ W, var, VA, PF = $\pm 0.5\%$ VAh = $\pm 2.0\%$ Wh = class 0.5S (IEC62053-22) varh = class 1S (IEC62053-24) Harmonics = 19 th -deg (max) Rolling demand = W, var, VA
ME96SSEB-MB (Economy model)	MODBUS RTU communication	A, DA, V = $\pm 0.5\%$ Hz = $\pm 0.2\%$ W, var, VA, PF = $\pm 0.5\%$ VAh = $\pm 2.0\%$ Wh = class 0.5S (IEC62053-22) varh = class 1S (IEC62053-24) Harmonics = Only total

Optional Plug-in Modules

Model name	Analog output	Pulse/Alarm output	Contact input	Contact output	Transmission function	Used with
ME-4210-SS96B	4	2	1	—	—	ME96SSHB-MB ME96SSRB-MB
ME-0040C-SS96	—	—	4	—	CC-Link	
ME-0052-SS96	—	—	5	2	—	
ME-0000BU-SS96	—	—	—	—	SD CARD	
ME-0000MT-SS96	—	—	—	—	MODBUS TCP	

Note: Optional Plug-in Module can not be used with ME96SSEB-MB.

MODBUS RTU System

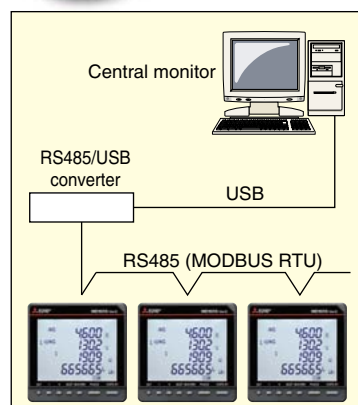

- MODBUS RTU communication system optimizes computer monitoring operations.
- In addition, when ME-0052-SS96 is installed, remote monitoring of contact input signals and on/off control of contact output signals are possible. Therefore, no other DI/DO terminals are required.
- Digital input signals can be latched for over 30ms, and there is no need for external latch circuits.

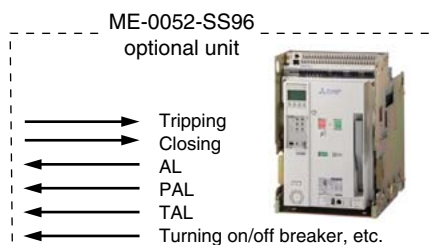

<MODBUS RTU Interface Specifications>

- Max. Baud rate: 38.4kbps
- Max. Connection Distance: 1,200m
- Max. Connection Units: 31

<Optional Plug-in Module ME-0052-SS96>

- Digital Input: 5 points (24VDC)
- Digital Output: 2 points (35VDC)

ME96 Super-S Series Ver.B Features

CC-Link System (ME96SSHB-MB/ME96SSRB-MB with ME-0040C-SS96 (optional plug-in module))

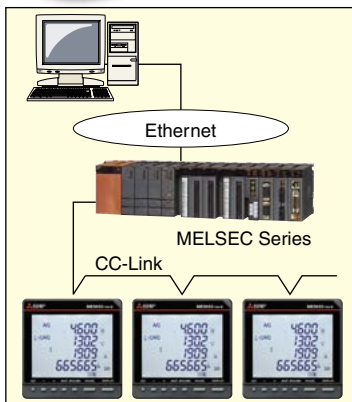

- Optimum transmission system for remote monitoring using Mitsubishi PLC
- Contact signals can be remotely monitored by installing the optional module ME-0040C-SS96. This is helpful in wiring and space saving.
- Digital unit signal can be latched for over 30ms, and there is no need for external latch circuits

- ← Abnormal Signal (Facility)
- ← Abnormal Signal (Earth Leakage)
- ← Abnormal Signal (Temperature)
- ← Circuit Breaker Status Signal, etc.

<CC-Link Interface>

- Max. Baud rate: 10Mbps
- Max. Connection Distance: 100m (10Mbps)-1,200m (156kbps)
- Max. Connection Units: 42
- Digital Input: 4 points (24VDC)

Analog/Pulse/Alarm Output System (ME96SSHB-MB/ME96SSRB-MB with ME-4210-SS96B (optional plug-in module))

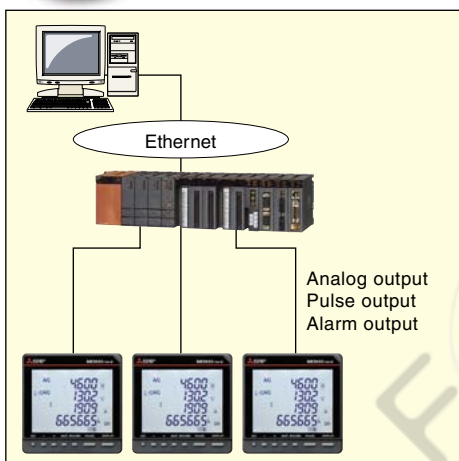

- Applicable to analog output, pulse output and alarm output with the aid of the optional module ME-4210-SS96B
- Remote monitoring of A, DA, V, W, var, VA, PF, Hz, Harmonics Current RMS value and Harmonics voltage RMS value at 4 to 20mA output (max. 4 outputs)
- Active energy, reactive energy, apparent power and periodic energy can be monitored by pulse output (max. 2 pulses)
- Can remotely monitor upper/lower limit alarm by contact output (max. 2 points)

<Analog output specifications>

- 4-20mA
- 4 outputs
- Resistance load 600Ω or less

<Pulse output specifications>

- No-voltage a contact point
- 35VDC, 0.1A
- Select output from pulse widths of 0.125, 0.5 or 1s

<Alarm output specifications>

- No-voltage a contact point
- 35VDC, 0.1A

<Digital input specifications>

- 1 point (24VDC)

MODBUS TCP Communication (ME96SSHB-MB/ME96SSRB-MB with ME-0000MT-SS96 (optional plug-in module))

- This is a MODBUS TCP communication unit that can be used in the Ethernet system. The number of network system selection methods is increased, and Ethernet and MODBUS RTU communication can be duplicated.

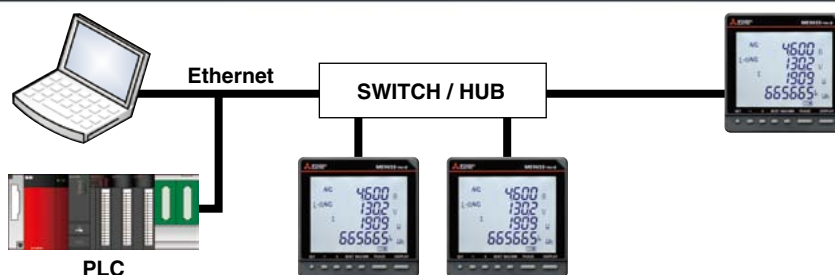

Data Logging (built-in logging function and optional plug-in module)

- ME96SSHB/ME96SSRB are available with built-in logging function and an optional module (ME-0000BU-SS96) which can retain data even when communication cannot be established.



CSV file data



Data in more than one logging unit can be managed with one SD memory card.

Note: Use the SD memory card (EMU4-SD2GB) made by Mitsubishi Electric.

Use of any memory card other than our product (EMU4-SD2GB) is not covered by the warranty.



ME96 Super-S Series Ver.B Features

Succeeded Display Functions

Concurrent Display of 4 items

The 4 measured values can be digitally confirmed on one screen.

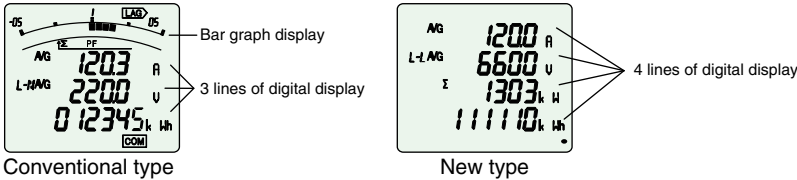

Concurrent Display of Each Phase Measured Values

In Display Pattern P02, measured values of each phase can be concurrently displayed.

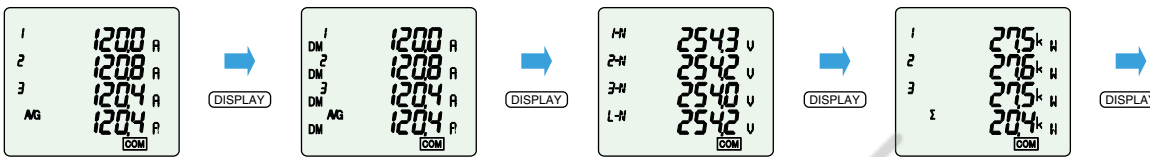

Cyclic Display Function

In the cyclic display function, the display screen can be changed over in every 5 seconds without [DISPLAY] button operation.

Special Display Function

Special Display by Display Pattern P00

Display can be selected as desired Display Pattern P00.

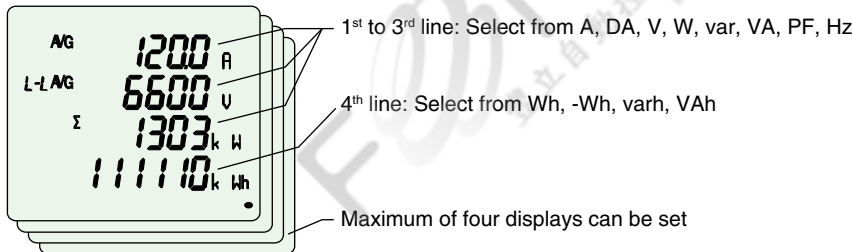

Max/Min Display Function

Maximum/Minimum Value Display

The maximum and minimum value of each measuring items can be displayed. Since the max/min display shows the current value as well as max/min values, the display can be used for monitoring.



Wide-viewing-angle (ME96SSHB-MB, ME96SSRB-MB)

As the wide-viewing-angle LCD is mounted, good visibility is obtained even when the instrument is mounted at a level lower than the eye line.

Type	Model number	When viewed from the side		When viewed from the above	
		Up	Down	Left	Right
New type	ME96SSHB-MB ME96SSRB-MB	60°	60°	60°	60°
Old type	ME96SSHA-MB ME96SSRA-MB	10°	60°	60°	60°

Note: ME96SSEB-MB has the same viewing angle as the old type.

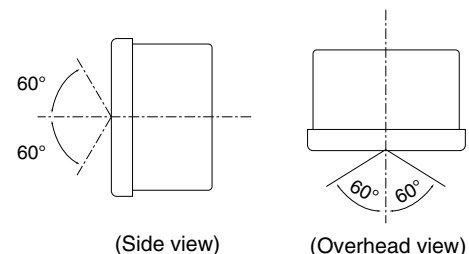



Impressive Monitoring Functions

Advanced Alarm Display

- (1) A function to blink the backlight upon occurrence of an alarm is provided.
The product has a setting function to blink the backlight upon occurrence of an alarm.
- (2) The automatic or manual alarm cancel mode can be selected.
- (3) Up to four points of upper and lower limits can be monitored.
- (4) The alarm output delay time (alarm mask time) can be set.
Time of alarm output after the maximum value and minimum value is reached can be set.
With this function, alarm output caused by frequency change at start-up current of a motor and start-up of private power generating facility can be avoided.

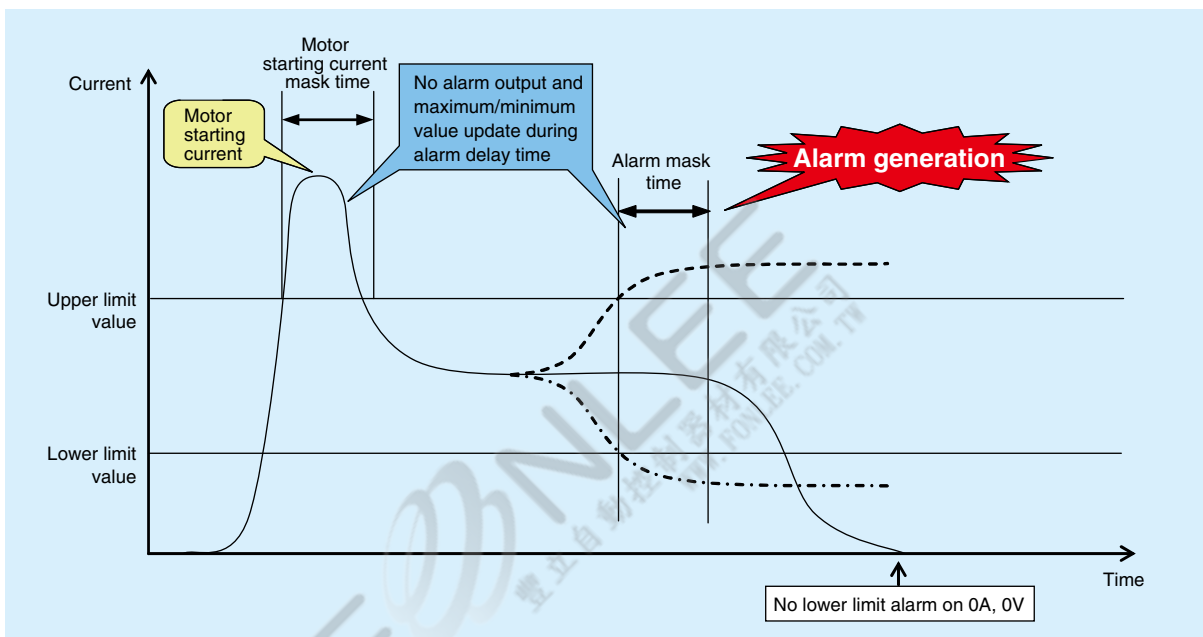

Motor Starting Current Mask Function

The use of the motor starting current mask function for monitoring the motor current can prevent updating of the maximum value and alarm output caused by the motor starting current.

Although the maximum value is not updated, the current value is displayed.

The starting current mask time can be set in the range from 1s to 5min.

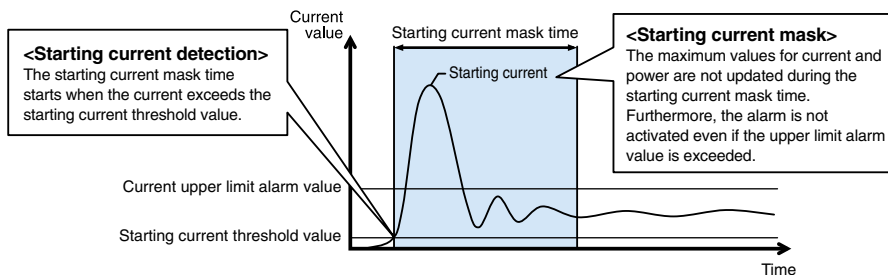

ME96 Super-S Series Ver.B Features



Variety of Complementary Features

Password Function

With the password function, the following items can be protected from an accidental execution.

No.	Password-protected item	No.	Password-protected item
1	Shift to the setting mode	5	Adjust the time limit of rolling demand
2	Reset the max./min. values	6	Reset the peak value of rolling demand
3	Reset the value of active energy, reactive energy and apparent energy	7	Reset the value of operating time
4	Reset the value of periodic active energy		

Special Primary Voltage/Current and Special Secondary Voltage are settable

(1) Special primary current

1A-30kA



(2) Special primary voltage

60V-750kV



(3) Special secondary voltage

Three phase 4-wire system

{ 63.5V, 100V, 110V, 115V, 120V }

Three phase 3-wire, Single phase 2-wire system

{ 100V, 110V, 220V }



Periodic Monitoring Function

Power consumption can be measured in three individual intervals (e.g., peak, off-peak and shoulder, etc.).

The time segments can be switched according to the setting via communication or the digital input (DI).
(The time segments cannot be switched manually (button operation).)



Power consumption (period 1)



Power consumption (period 2)



Power consumption (period 3)

Rolling Demand Function

Rolling demand is the estimated power consumption in a specified period (interval).

For the block interval demand, select the duration (interval) of the block to be used for demand calculation.

① Rolling block

Use rolling block to set the interval and sub-intervals from 1-60min (1min intervals). Rolling demand is calculated and updated at the end of each sub-interval. However, Present and predictive values are always calculated.

<Example: Interval, 15min; Sub-interval, 5min>

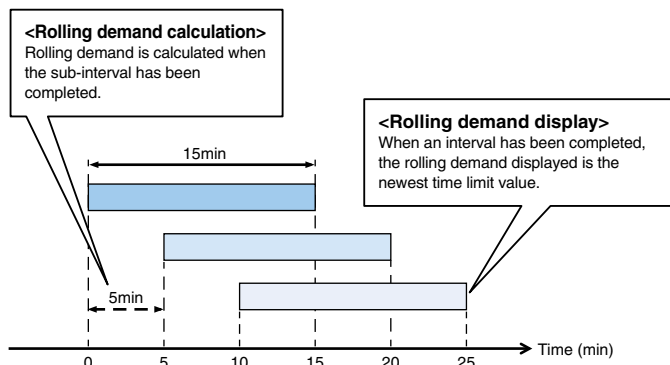

② Fixed block

Use fixed block to set the interval from 1-60min (1min intervals). Rolling demand is calculated and updated at the end of each interval. However, Present and predictive values are always calculated.
(For fixed block, use the same time limits both of interval and sub-interval).

<Example: Interval, 15min; Sub-interval, 15min>

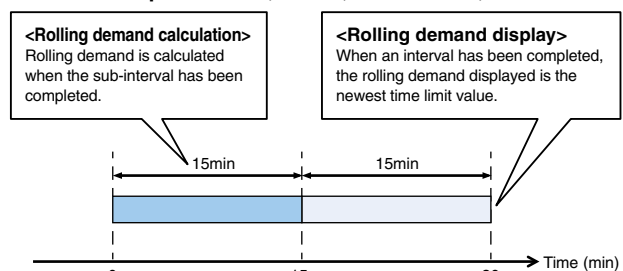



Test Function

- A test function is provided to check the wiring for communication, alarm output/contact output, analog output and pulse output without input of voltage or current.
- At the time of wiring test before shipment of the board and counter test for system validation on site, test signals can be output only by applying the auxiliary power.
Note: Depending on the optional unit and settings, the test function may not be available (may not be displayed).

(1) Communications Test

- Display
 - The same as for the operating mode, display patterns and other data are shown as set.
 - Both maximum and minimum values can be displayed.
- Communication data
 - Communication items and value are the same one on the display. The items value that are not displayed is 0 (zero).
 - Measuring items set for alarm will be displayed at the time of an alarm.
 - Input/Output contact status can be monitored.

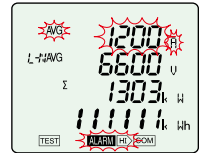

(2) Alarm/Contact Output Operation Test

- Displays current alarm and contact status.
- Press the Reset button for 2sec, and regardless if there is an alarm or not, the display and contact output will operate as follows.

Status	Display	Output terminal
Alarm	ON	Closed
No alarm	OFF	Open



(3) Analog Output Operation Test

- Display the output items.
- Press the (+) or (-) button to change the analog output.
Note: Default value is 0%.

Output	Output specs
	4-20mA
0%	4mA
25%	8mA
50%	12mA
75%	16mA
100%	20mA

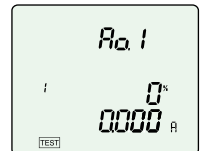

(4) Pulse Output Operation Test

Press the Reset button one time to output one pulse.

Note: After reaching 50, count will return to 1.

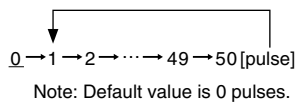

Checking Input Wiring Support Function

(1) Incorrect wiring pattern display function

- Whether the voltage/current input wirings are correct or not is displayed. As for the incorrect wiring display pattern, see the instruction manual.



Normal state

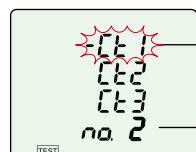

When Side 1 CT is inversely connected

Incorrectly connected spot is displayed in blinking.
Incorrect wiring pattern No. is displayed.

Note 1: When wiring of either one of the current/voltage terminals is not correct, the incorrectly connected spot is easily identified.

Note 2: Not all incorrect wirings can be identified. When the voltage input is incorrectly connected and the current input is also incorrectly connected, a different pattern of incorrect wiring may be displayed.



When incorrect wiring pattern cannot be detected

Display	Content	Display	Content
01	Low voltage	03	Voltage unbalance
02	Low current	04	Incorrect connections at multiple spots

Check by using the incorrect wiring identification support display function.

(2) Incorrect Wiring Identification Support Display Function

- This function displays each phase angle (voltage side 1 standard) of voltage and current, power values (W1, W2, W3) of each phase, voltage value & current values to support identifying incorrect wirings. By knowing abnormality in the phase angle of voltage/current and by comparing it with the normal value, you can more easily identify an incorrectly wired spot.
- Examples of screen displays of incorrect wiring identification support function.

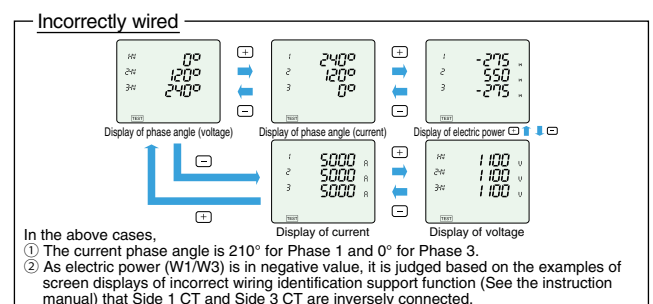
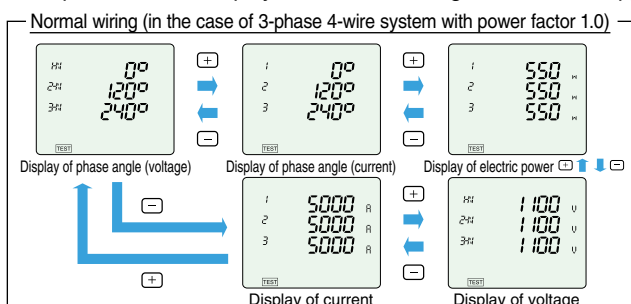

Standards

All products are compliant with CE Marking, UL Standards, KC mark and FCC/IC.

Specifications

ME96SSHB-MB

Model name		ME96SSHB-MB		
Phase wire system		3-phase 4-wire, 3-phase 3-wire (3CT, 2CT), 1-phase 3-wire, 1-phase 2-wire (common use)		
Rating	Current	5 A AC, 1 A AC (common use)		
	Voltage	3-phase 4-wire: max 277/480 V AC 3-phase 3-wire: (DELTA) max 220 V AC, (STAR) max 440 V AC 1-phase 3-wire: max 220/440 V AC 1-phase 2-wire: (DELTA) max 220 V AC, (STAR) max 440 V AC		
	Frequency	50/60 Hz (common use)		
Item	Measuring Item	Class		
Measuring element	Current (A)	A1, A2, A3, AN, A _{AVG}	±0.1%	
	Current demand (DA)	DA1, DA2, DA3, DAN, DA _{AVG}	±0.1%	
	Voltage (V)	V12, V23, V31, V _{AVG} (L-L), V1N, V2N, V3N, V _{AVG} (L-N)	±0.2%	
	Active power (W)	W1, W2, W3, ΣW	±0.2%	
	Reactive power (var)	var1, var2, var3, Σvar	±0.2%	
	Apparent power (VA)	VA1, VA2, VA3, ΣVA	±0.2%	
	Power factor (PF)	PF1, PF2, PF3, ΣPF	±0.2%	
	Frequency (Hz)	Hz	±0.1%	
	Active energy (Wh)	Imported, Exported	Class 0.5S (IEC62053-22)	
	Reactive energy (varh)	Imported lag, Imported lead, Exported lag, Exported lead	Class 1S (IEC62053-24)	
	Apparent energy (VAh)	Imported + Exported	±2.0%	
	Harmonic current (HI)	Total, 1 st to 31 st (Odd degree only)	±1.0%	
	Harmonic voltage (HV)	Total, 1 st to 31 st (Odd degree only)	±1.0%	
	Rolling demand active power (DW)	Rolling block, Fixing block (Select either of them according to the settings.)	±0.2%	
	Rolling demand reactive power (Dvar)	Rolling block, Fixing block (Select either of them according to the settings.)	±1.0%	
	Rolling demand apparent power (DVA)	Rolling block, Fixing block (Select either of them according to the settings.)	±1.0%	
	Periodic active energy (Wh)	Periodic active energy 1, Periodic active energy 2, Periodic active energy 3	Class 0.5S	
	Operating time (h)	Operating time 1, Operating time 2	(Reference)	
Current unbalance rate (Aunb)	Aunb	(Reference)		
Voltage unbalance rate (Vunb)	Vunb	(Reference)		
CO ₂ equivalent	kg	(Reference)		
Item	Specifications			
Analog output response time		1 second or less (Hz: 2 seconds or less, HI, HV: 5 seconds or less)		
Measuring Method	Instantaneous Value	A, V: RMS value calculation; W, var, VA, Wh, varh, VAh: Digital multiplication; PF: Power ratio calculation; Hz: Zero-cross; HI, HV: FFT		
	Demand Value	DA: Thermal type calculation, DW, Dvar, DVA: Rolling demand calculation		
Display	Display type		LCD with LED backlight	
	Number of display digits or segments	Digital section	First to third line indication: 4 digits, Fourth line indication: 6 digits A, DA, V, W, var, VA, PF, DW, Dvar, DVA: 4 digits; Hz: 3 digits; Wh, varh, VAh: 9 digits (6-digit or 12-digit is also available.); Harmonic distortion ratio/content rate: 4 digits; Harmonic RMS value: 4 digits; Operating time: 6 digits; Contact input/output: I/O	
			Display update time interval	0.5 s, 1 s (selectable)
Communication		MODBUS RTU communication		
Built-in logging	Logging mode		Automatic overwrite update	
	Logging data type	Measuring data *1	Measuring data and time data are logged at the interval set at the data logging period. (15 min, 30 min, 60 min)	
		Alarm log	Time data at alarm generating/cancellation and at waiting for alarm cancellation	
		The recorded time of the Max/Min value	Max/Min value data and time data	
	Number of logging items	Measuring data	Integrated value data: 5 items, Data other than integrated value: 15 items, Total: A maximum of 20 items	
		Alarm log	The number of the set alarms	
	Internal memory logging period	The recorded time of the Max/Min value	The total is 19 items: Current Max/Min (AVG), Line voltage Max/Min (AVG), Phase voltage Max/Min (AVG), Total active power Max/Min (AVG), Total power factor Max/Min (AVG), Frequency Max/Min (AVG), Total reactive power Max/Min, Total apparent power Max/Min, Total harmonic current RMS Max value, Harmonic line voltage distortion ratio Max total, Harmonic phase voltage distortion ratio Max total	
		Measuring data	30 days (Logging period: 15 minutes), 60 days (Logging period: 30 minutes), 120 days (Logging period: 60 minutes),	
		Alarm log	100 records	
	The recorded time of the Max/Min value	1 record for every Max/Min value factor		
System log data		100 records		
Saving logging data		Use of nonvolatile memory		
How to acquire logging data		Acquire the logging data via MODBUS [®] RTU Communication		
Clock accuracy		1 minute difference/Month (typical)		
Connectable Optional Plug-in Module		ME-4210-SS96B, ME-0040C-SS96, ME-0052-SS96, ME-0000MT-SS96, ME-0000BU-SS96		
Analog output	Output specifications (Load)	4 mA to 20 mA DC (0 to 600 Ω)		
	Switch type	Semiconductor relay/No-voltage a-contact		
Pulse/Alarm output	Contact capacity	35 V DC, 0.1 A		
	Pulse width	0.125 s, 0.5 s, 1.0 s		
Contact input (DI)	Contact capacity	24 V DC (19 V to 30 V DC), 7 mA or less		
	Signal width	30 ms or more		
Contact output (DO)	Switch type	Semiconductor relay/No-voltage a-contact		
Power interruption backup	Use of nonvolatile memory (Items: settings, MAX/MIN value, active energy, reactive energy, apparent energy, periodic active energy, rolling demand, operating time)			
	Built-in logging	Use of nonvolatile memory (Logging data, System log data)		
VA Consumption	Voltage circuit	Each phase: 0.1 VA (at 110 V AC), 0.2 VA (at 220 V AC), 0.4 VA (at 440 V AC)		
	Current circuit	Each phase: 0.1 VA		
	Auxiliary power circuit	13 VA (at 110 V AC), 14 VA (at 220 V AC), 9 W (at 100 V DC)		
Auxiliary power		100 V to 240 V AC (±15%), 100 V to 240 V DC (-30% +15%)		
Weight		0.5 kg		
Dimensions		96 (H) × 96 (W) × 90 (D) mm		
Mounting method		Embedded		
Operating temperature/humidity		-5°C to +55°C (Daily average temperature: 35°C or less), 0% to 85% RH, Non condensing		
Storage temperature/ humidity		-25°C to +75°C (Daily average temperature: 35°C or less), 0% to 85% RH, Non condensing		

Note 1. The class value represents the ratio to the rated value (100%).

Note 2. For measurement where the harmonic distortion ratio (content rate) is 100% or more, the class can exceed ±1.0%.

Note 3. Harmonic current cannot be measured without voltage input.

Note 4. Using the conventional ME-4210-SS96 (Optional Plug-in Module), the CE marking and UL standards safety certification requirements cannot be met.

*1: Integrated values (Wh, varh, and VAh) are measured values of ME96SS. They are not differential values by logging period.



ME96SSRB-MB

Model name		ME96SSRB-MB	
Phase wire system		3-phase 4-wire, 3-phase 3-wire (3CT, 2CT), 1-phase 3-wire, 1-phase 2-wire (common use)	
Rating	Current	5 A AC, 1 A AC (common use)	
	Voltage	3-phase 4-wire: max 277/480 V AC 3-phase 3-wire: (DELTA) max 220 V AC, (STAR) max 440 V AC 1-phase 3-wire: max 220/440 V AC 1-phase 2-wire: (DELTA) max 220 V AC, (STAR) max 440 V AC	
	Frequency	50/60 Hz (common use)	
Item		Measurement items	Class
Measuring element	Current (A)	A1, A2, A3, AN, A _{AVG}	±0.2%
	Current demand (DA)	DA1, DA2, DA3, DAN, DA _{AVG}	
	Voltage (V)	V12, V23, V31, V _{AVG} (L-L), V1N, V2N, V3N, V _{AVG} (L-N)	
	Active power (W)	W1, W2, W3, ΣW	±0.5%
	Reactive power (var)	var1, var2, var3, Σvar	
	Apparent power (VA)	VA1, VA2, VA3, ΣVA	
	Power factor (PF)	PF1, PF2, PF3, ΣPF	±0.1%
	Frequency (Hz)	Hz	
	Active energy (Wh)	Imported, Exported	
	Reactive energy (varh)	Imported lag, Imported lead, Exported lag, Exported lead	Class 1S (IEC62053-24)
	Apparent energy (VAh)	Imported + Exported	±2.0%
	Harmonic current (HI)	Total, 1 st to 19 th (Odd degree only)	±1.0%
	Harmonic voltage (HV)	Total, 1 st to 19 th (Odd degree only)	
	Rolling demand active power (DW)	Rolling block, Fixing block (Select either of them according to the settings.)	±0.5%
	Rolling demand reactive power (Dvar)	Rolling block, Fixing block (Select either of them according to the settings.)	±1.0%
	Rolling demand apparent power (DVA)	Rolling block, Fixing block (Select either of them according to the settings.)	
	Periodic active energy (Wh)	Periodic active energy 1, Periodic active energy 2, Periodic active energy 3	Class 0.5S
	Operating time (h)	Operating time 1, Operating time 2	(Reference)
Current unbalance rate (Aunb)	Aunb	(Reference)	
Voltage unbalance rate (Vunb)	Vunb	(Reference)	
CO ₂ equivalent	kg	(Reference)	
Item		Specifications	
Analog output response time		1 second or less (Hz: 2 seconds or less, HI, HV: 5 seconds or less)	
Measuring Method	Instantaneous Value	A, V: RMS value calculation; W, var, VA, Wh, varh, VAh: Digital multiplication; PF: Power ratio calculation; Hz: Zero-cross; HI, HV: FFT	
	Demand Value	DA: Thermal type calculation, DW, Dvar, DVA: Rolling demand calculation	
Display	Display type		LCD with LED backlight
	Number of display digits or segments	Digital section	First to third line indication: 4 digits, Fourth line indication: 6 digits A, DA, V, W, var, VA, PF, DW, Dvar, DVA: 4 digits; Hz: 3 digits; Wh, varh, VAh: 9 digits (6-digit or 12-digit is also available.); Harmonic distortion ratio/content rate: 4 digits; Harmonic RMS value: 4 digits; Operating time: 6 digits; Contact input/output: I/O
			Display update time interval
Communication		MODBUS RTU communication	
Built-in logging	Logging mode		Automatic overwrite update
	Logging data type	Measuring data *1	Measuring data and time data are logged at the interval set at the data logging period. (15 min, 30 min, 60 min)
		Alarm log	Time data at alarm generating/cancellation and at waiting for alarm cancellation
		The recorded time of the Max/Min value	Max/Min value data and time data
	Number of logging items	Measuring data	Integrated value data: 5 items, Data other than integrated value: 15 items, Total: A maximum of 20 items
		Alarm log	The number of the set alarms
		The recorded time of the Max/Min value	The total is 19 items: Current Max/Min (AVG), Line voltage Max/Min (AVG), Phase voltage Max/Min (AVG), Total active power Max/Min (AVG), Total power factor Max/Min (AVG), Frequency Max/Min (AVG), Total reactive power Max/Min, Total apparent power Max/Min, Total harmonic current RMS Max value, Harmonic line voltage distortion ratio Max total, Harmonic phase voltage harmonic distortion ratio Max total
	Internal memory logging period	Measuring data	30 days (Logging period: 15 minutes), 60 days (Logging period: 30 minutes), 120 days (Logging period: 60 minutes)
		Alarm log	100 records
		The recorded time of the Max/Min value	1 record for every Max/Min value factor
System log data		100 records	
Saving logging data		Use of nonvolatile memory	
How to acquire logging data		Acquire the logging data via MODBUS [®] RTU Communication	
Clock accuracy		1 minute difference/Month (typical)	
Connectable Optional Plug-in Module		ME-4210-SS96B, ME-0040C-SS96, ME-0052-SS96, ME-0000MT-SS96, ME-0000BU-SS96	
Analog output	Output specifications (Load)	4 mA to 20 mA DC (0 to 600 Ω)	
Pulse/Alarm output	Switch type	Semiconductor relay/No-voltage a-contact	
	Contact capacity	35 V DC, 0.1 A	
	Pulse width	0.125 s, 0.5 s, 1.0 s	
Contact input (DI)	Contact capacity	24 V DC (19 V to 30 V DC), 7 mA or less	
	Signal width	30 ms or more	
Contact output (DO)	Switch type	Semiconductor relay/No-voltage a-contact	
Power interruption backup	Use of nonvolatile memory (Items: settings, MAX/MIN value, active energy, reactive energy, apparent energy, periodic active energy, rolling demand, operating time)		
	Built-in logging	Use of nonvolatile memory (Logging data, System log data)	
VA Consumption	Voltage circuit	Each phase: 0.1 VA (at 110 V AC), 0.2 VA (at 220 V AC), 0.4 VA (at 440 V AC)	
	Current circuit	Each phase: 0.1 VA	
	Auxiliary power circuit	13 VA (at 110 V AC), 14 VA (at 220 V AC), 9 W (at 100 V DC)	
Auxiliary power		100 V to 240 V AC (±15%), 100 V to 240 V DC (-30% +15%)	
Weight		0.5 kg	
Dimensions		96 (H) × 96 (W) × 90 (D) mm	
Mounting method		Embedded	
Operating temperature/humidity		-5°C to +55°C (Daily average temperature: 35°C or less), 0% to 85% RH, Non condensing	
Storage temperature/ humidity		-25°C to +75°C (Daily average temperature: 35°C or less), 0% to 85% RH, Non condensing	

Note 1. The class value represents the ratio to the rated value (100%).

Note 2. For measurement where the harmonic distortion ratio (content rate) is 100% or more, the class can exceed ±1.0%.

Note 3. Harmonic current cannot be measured without voltage input.

Note 4. Using the conventional ME-4210-SS96 (Optional Plug-in Module), the CE marking and UL standards safety certification requirements cannot be met.

*1: Integrated values (Wh, varh, and VAh) are measured values of ME96SS. They are not differential values by logging period.

Specifications

ME96SSEB-MB

Model name		ME96SSEB-MB	
Phase wire system		3-phase 4-wire, 3-phase 3-wire (3CT, 2CT), 1-phase 3-wire, 1-phase 2-wire (common use)	
Rating	Current	5 A AC, 1 A AC (common use)	
	Voltage	3-phase 4-wire: max 277/480 V AC 3-phase 3-wire: (DELTA) max 220 V AC, (STAR) max 440 V AC 1-phase 3-wire: max 220/440 V AC 1-phase 2-wire: (DELTA) max 220 V, (STAR) max AC 440 V AC	
	Frequency	50/60 Hz (common use)	
Item		Measuring Item	Class
Measuring element	Current (A)	A1, A2, A3, AN, A _{AVG}	±0.5%
	Current demand (DA)	DA1, DA2, DA3, DAN, DA _{AVG}	
	Voltage (V)	V12, V23, V31, V _{AVG} (L-L), V1N, V2N, V3N, V _{AVG} (L-N)	
	Active power (W)	W1, W2, W3, ΣW	
	Reactive power (var)	var1, var2, var3, Σvar	
	Apparent power (VA)	VA1, VA2, VA3, ΣVA	
	Power factor (PF)	PF1, PF2, PF3, ΣPF	±0.5%
	Frequency (Hz)	Hz	±0.2%
	Active energy (Wh)	Imported, Exported	Class 0.5S (IEC62053-22)
	Reactive energy (varh)	Imported lag, Imported lead, Exported lag, Exported lead	Class 1S (IEC62053-24)
	Apparent energy (VAh)	Imported + Exported	±2.0%
	Harmonic current (HI)	Total	±2.0%
	Harmonic voltage (HV)	Total	
Operating time (h)	Operating time 1, Operating time 2	(Reference)	
Measuring method	Instantaneous value	A, V: RMS value calculation; W, var, VA, Wh, varh, VAh: Digital multiplication; PF: Power ratio calculation; Hz: Zero-cross; HI, HV: FFT	
	Demand value	DA: Thermal type calculation	
Display	Display type		LCD with LED backlight
	The number of display digits or The number of segments	Digital section	First to Third line display: 4 digits, Fourth line display: 6 digits
			A, DA, V, W, var, VA, PF: 4 digits; Hz: 3 digits; Wh, varh, VAh: 9 digits (6-digit or 12-digit is also available.); Harmonic distortion ratio/content rate: 4 digits; Harmonic RMS value: 4 digits; Operating time: 6 digits
	Display update time interval		0.5 s, 1 s (selectable)
Communication		MODBUS RTU communication	
Connectable Optional Plug-in Module		Cannot connect optional module	
Power interruption backup		Use of nonvolatile memory (Items: settings, MAX/MIN value, active energy, reactive energy, apparent energy, operating time)	
VA consumption	Voltage circuit	Each phase: 0.1 VA (at 110 V AC), 0.2 VA (at 220 V AC), 0.4 VA (at 440 V AC)	
	Current circuit	Each phase: 0.1 VA	
	Auxiliary power circuit	4 VA (at 110 V AC), 5 VA (at 220 V AC), 3 W (at 100 V DC)	
Auxiliary power		100 V to 240 V AC (±15%), 100 V to 240 V DC (-30% +15%)	
Weight		0.3 kg	
Dimensions		96 (H) × 96 (W) × 36 (D) mm	
Mounting method		Embedded	
Operating temperature/humidity		-5°C to +55°C (Daily average temperature: 35°C or less), 0% to 85% RH, Non condensing	
Storage temperature/ humidity		-25°C to +75°C (Daily average temperature: 35°C or less), 0% to 85% RH, Non condensing	

Note 1. The class value is a percentage of rated value (100%).

Note 2. For harmonics measurement where distortion ratio (content rate) is 100% or more, it can exceed ±2.0%.

Note 3. When there is no voltage input, harmonic current cannot be measured.



Standards Compliance

Electromagnetic Compatibility		
Emissions		
Radiated Emission		EN 61326-1 / EN 55011, CISPR 11 FCC Part15 Subpart B Class A
Conducted Emission		EN 61326-1 / EN 55011, CISPR 11 FCC Part15 Subpart B Class A
Harmonics Measurement		EN 61000-3-2
Flicker Meter Measurement		EN 61000-3-3
Immunity		
Electrostatic discharge Immunity		EN 61326-1, EN IEC 61000-6-2 / EN 61000-4-2
Radio Frequency Electromagnetic field Immunity		EN 61326-1, EN IEC 61000-6-2 / EN 61000-4-3
Electrical Fast Transient/Burst Immunity		EN 61326-1, EN IEC 61000-6-2 / EN 61000-4-4
Surge Immunity		EN 61326-1, EN IEC 61000-6-2 / EN 61000-4-5
Conducted Disturbances, Induced By Radio Frequency Fields Immunity		EN 61326-1, EN IEC 61000-6-2 / EN 61000-4-6
Power Frequency Magnetic Field Immunity		EN 61326-1, EN IEC 61000-6-2 / EN 61000-4-8
Voltage Dips and Short Interruptions		EN 61326-1, EN IEC 61000-6-2 / EN 61000-4-11
Safety		
Europe		CE, as per EN61010-1: 2010 (3 rd Edition)
U.S. and Canada		UL Recognized Component as per UL 61010-1, IEC 61010-1
Installation Category		III
Measuring Category		III
Pollution Degree		2

MODBUS RTU Communication Specifications

Item	Specification
Interface	RS-485 2-wire half-duplex transmission
Protocol	RTU (binary data transfer)
Transmission method	Asynchronous
Connection type	Multi-point bus
Baud rate	2400, 4800, 9600, 19200, 38400bps
Data bit	8
Stop bit	1, 2
Parity	ODD, EVEN, NONE
Address	1 to 255 (0: for broadcast mode)
Distance	1,200m (max)
Max. connectable units	31 units
Terminal Resistance	120Ω 1/2W
Recommended Cable	Shielded twisted-pair AWG24 to 14

- For more information on data, please refer to the following document.
 - Electronic Multi-Measuring Instrument ME series MODBUS Interface specifications...LSPM-0075

CC-Link Communication Specifications for optional plug-in module

Item	Specification
No. of occupied stations	1 Station Remote device station
CC-Link version	CC-Link Ver 1.10 / Ver 2.00
Baud rate	10Mbps / 5Mbps / 2.5Mbps / 625kbps / 156kbps
Transmission method	Broadcast polling system
Synchronous method	Frame synchronous system
Encoding method	NRZI
Transmission path format	Bus format (EIA RS485)
Transmission format	HDLC
Error control system	CRC ($X^{16} + X^{12} + X^5 + 1$)
Number of connectable units	42 units (max, remote device station)
Remote station numbers (station numbers)	1 to 64

- For CC-Link connection cables, please use the dedicated cables.
 - For information regarding dedicated cables, please refer to the CC-Link Partner Product Catalog published by the CC-Link Partner Association or CC-Link Partner Product Information on the CC-Link Partner Association website (<http://www.cc-link.org>).
 - Notes 1. Dedicated CC-Link cables compatible with Ver. 1.00 cannot be used in tandem with dedicated CC-Link high-performance cables compatible with Ver. 1.00.
 - Notes 2. In the case of systems consisting of units compatible with Ver. 1.00, 1.10 or 2.00 used in tandem with Ver. 1.00 or 1.10 cables, Ver. 1.00 specifications will apply for the maximum total cable length and length of cables between stations.
 - Notes 3. For terminal resistance, be sure to use 110 Ω ±5% (1/2W product) when using dedicated CC-Link cables or 130 Ω ±5% (1/2W product) when using dedicated CC-Link high-performance cables.
- For more information on data, please refer to the following document.
 - Electronic Multi-Measuring Instrument programming manual (CC-Link).....LEN080334
 - Electronic Multi-Measuring Instrument programming manual (CC-Link)(For ver. 2 remote device station)...LEN130391

Input/Output Specifications

Item	Specification	Optional Plug-in Module type
Analog output	4-20mA (0-600 Ω)	ME-4210-SS96B
Pulse/Alarm output	No-voltage "a" contact Capacity: 35VDC, 0.1A	ME-4210-SS96B
Digital input	19-30VDC 7mA or less	ME-4210-SS96B, ME-0040C-SS96, ME-0052-SS96
Digital output	No-voltage a contact Capacity: 35VDC, 0.2A	ME-0052-SS96

Specifications

■ MODBUS TCP Communication Specifications for optional plug-in module

Item		Specification
Interface		1 port (10BASE-T/100BASE-TX)
Transmission method		Base band
Number of stages connected in cascade		Max. 4 stages (10BASE-T), max. 2 stages (100BASE-TX) (when repeater hub is used)
Max. distance between nodes		200m
Max. segment length		100m
Connector applicable to external wiring		RJ45
Cable	10BASE-T	Cable meeting IEEE802.3 10BASE-T standard (Unshielded twisted pair cable (UTP cable), category 3 or higher)
	100BASE-TX	Cable meeting IEEE802.3 100BASE-TX standard (Shielded twisted pair cable (STP cable), category 5 or higher)
Protocol		MODBUS TCP (port No.502)
Max. number of connections		4
Support functions		Auto-negotiation function (automatic recognition of 10BASE-T/100BASE-TX) Auto-MDIX function (automatic recognition of straight cable/cross cable)

■ For more information on data, please refer to the following document.
Electronic Multi-Measuring Instrument ME series MODBUS Interface specifications...LSPM-0075

■ Logging Specifications for optional plug-in module

Item		Specification
Logging mode		Automatic updating by overwriting (not provided with a function to automatically start according to the start time setting)
Kinds of logging data	Detailed data	Measurement data is stored at the specified "detailed data logging interval" (1 min, 5 min, 10 min, 15 min or 30 min). Note: The data will be output as a detailed data file. Note: As the integrated values, not the difference values, but the values displayed on the multi indicating instrument will be output.
	1-hour data	Measurement data is stored at a one-hour interval. Note: The data will be output as a one-hour data file or a one-day data file. Note: As the integrated values, not the difference values, but the values displayed on the multi indicating instrument will be output.
Number of logging elements	Detailed data	Max. 6 elements
	1-hour data	Max. 6 elements
Internal memory logging period	Detailed data	Detailed data logging interval: 1 min for 2 days Detailed data logging interval: 5 min for 10 days Detailed data logging interval: 10 min for 20 days Detailed data logging interval: 15 min for 30 days Detailed data logging interval: 30 min for 60 days
	1-hour data	400 days (about 13 months)
SD memory card (2GB) logging period		10 years or more
System log data		1200 records
Logging data / system log data output format		CSV format (ASCII code)
Power failure compensation		Backup by built-in lithium battery Total power interruption backup time: 5 years (at daily average temperature of 35°C or less) (The life of the lithium battery is 10 years (at a daily average temperature of 35°C or less).) The battery cannot be replaced by the customer. Please consider updating the module.
Set values	(logging ID, logging elements and detailed data logging interval)	Stored in FRAM (non-volatile memory) Note: The data will not be deleted even if power interruption is caused by battery voltage drop (BAT. LED is on).
Logging data and system log data		Stored in SRAM (volatile memory) Note: The data will be deleted if power interruption is caused by battery voltage drop (BAT. LED is on).
Clock operation		Note: The clock operation will stop if power interruption is caused by battery voltage drop (BAT. LED is on). After power restoration, the clock operation will start from 00:00 on Jan. 1, 2016.
Clock accuracy		1 min / month
Output data storage medium		SD memory card (SD or SDHC)
Optional accessory		SD memory card (EMU4-SD2GB) *1

*1: Use the SD memory card (EMU4-SD2GB) made by Mitsubishi Electric.
Use of any memory card other than our product (EMU4-SD2GB) is not covered by the warranty.

■ For more information on data, please refer to the following document.
Logging specifications...LSPM-0092

Operating Instructions

Functions

LCD Functions

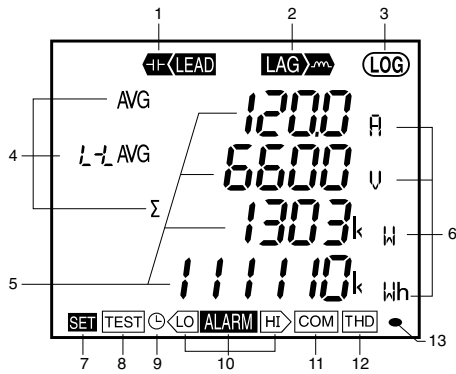

No.	Name of each part	Function																
1	LEAD status	Light up when leading reactive energy is measured																
2	LAG status	Light up when lagging reactive energy is measured																
3	Built-in logging status	Light up when the built-in logging function is operating																
4	Digital element display	Display measuring elements expressed in digital numbers																
5	Digital display	Display measured values in digital numbers																
6	Unit	Display the units of measured values																
7	Setup status	Light up in the setting mode Blink in the setting confirmation mode																
8	Test mode status	Light up in the test mode																
9	Clock status	Light up when the date and time are set																
10	Upper/lower limit alarm status	Blink when the upper/lower limit alarm is generating																
11	Communication/ Option logging status	<table border="1"> <thead> <tr> <th>Specification</th> <th>ON</th> <th>Blink</th> <th>OFF</th> </tr> </thead> <tbody> <tr> <td>CC-Link communication</td> <td>Normal</td> <td>CC-Link version mismatches, Hardware abnormality</td> <td>Hardware abnormality</td> </tr> <tr> <td>MODBUS RTU communication MODBUS TCP communication</td> <td>Normal</td> <td>Communication error such as wrong address *1</td> <td>Hardware abnormality</td> </tr> <tr> <td>Logging function</td> <td>Normal</td> <td>Error occurrence such as setting abnormality, SD memory card error, or battery voltage drop *1</td> <td>Hardware abnormality</td> </tr> </tbody> </table>	Specification	ON	Blink	OFF	CC-Link communication	Normal	CC-Link version mismatches, Hardware abnormality	Hardware abnormality	MODBUS RTU communication MODBUS TCP communication	Normal	Communication error such as wrong address *1	Hardware abnormality	Logging function	Normal	Error occurrence such as setting abnormality, SD memory card error, or battery voltage drop *1	Hardware abnormality
		Specification	ON	Blink	OFF													
		CC-Link communication	Normal	CC-Link version mismatches, Hardware abnormality	Hardware abnormality													
MODBUS RTU communication MODBUS TCP communication	Normal	Communication error such as wrong address *1	Hardware abnormality															
Logging function	Normal	Error occurrence such as setting abnormality, SD memory card error, or battery voltage drop *1	Hardware abnormality															
*1. For details, refer to User's Manual.																		
12	Harmonics	Light up when harmonic is displayed																
13	Metering status	Blink when Imported active energy is measured *Note 1 *It appears on the imported active energy display screen only																

Note 1. The blinking cycle is constant regardless of measuring input size.

Button Functions

Basic performance		Special performance	
Button operation	Functions	Button operation	Functions
SET	Used to set items such as primary voltage and current, and to choose setting items	DISPLAY (Push for 2 seconds)	Used to switch display between manual display change ↔ cyclic display change
+ or -	Used to switch display between setting	PHASE (Push for 2 seconds)	Used to switch display between manual phase change ↔ cyclic phase change
MAX/MIN	Used to switch display between max/min values and instantaneous value	+ + - (Push for 2 seconds)	Used to change Wh, etc. to another unit and to low order zoom display
PHASE	Used to change over phase	+ + RESET (Push for 2 seconds)	Used to perform batch reset of all the max/min values
DISPLAY	Used to change over the display screen	+ or - (Push for 1 seconds)	Used to perform fast-forward or fast-return of numerical values in numerical value setting
		SET + RESET + PHASE (Used to reset Wh, varh, and VAh to zero by concurrently pushing for 2 seconds)	

Note. An example. For details, refer to the user's manual.

Set-up

For correct measurement, it is necessary to set the primary voltage/current in the set-up mode.

Enter the setting mode from the operating mode and set the necessary items. Any items not set remain in the factory default.

Set-up workflow (Example for ME96SSH-B)

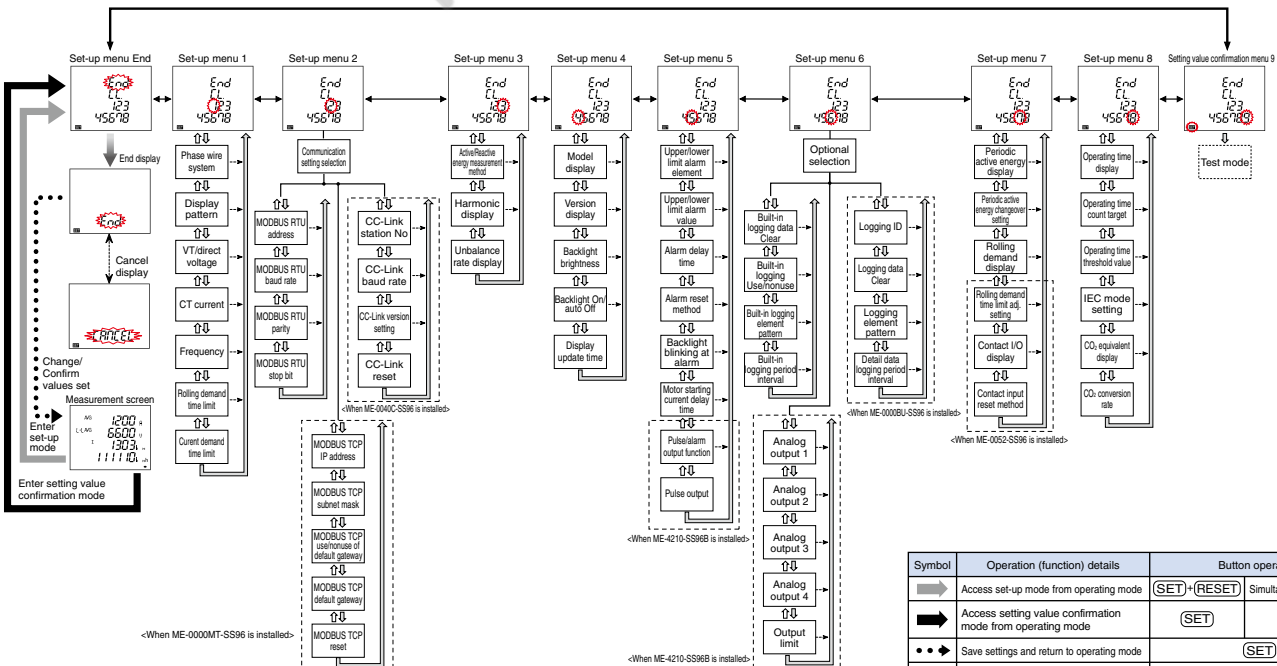

Notes 1. Basic measurements are possible by adjusting settings in the menu 1 () area enclosed by dotted line.
 Notes 2. Item settings vary depending on the model.
 Notes 3. Setting confirmation menu 9 (test mode) is not displayed in the setting mode.

Symbol	Operation (function) details	Button operation
→	Access set-up mode from operating mode	SET + RESET Simultaneously press for 2s
→	Access setting value confirmation mode from operating mode	SET Press for 2s
◆◆◆	Save settings and return to operating mode	SET
←	Select set-up menu	+ or -
⇐	Move to next screen	SET
⇐	Return to previous setting item	DISPLAY
→	Skip remaining settings	SET Press for 1s
←	Select cancel	+ or -

Operating Instructions

● Basic Set-up Operations

To access the setting mode, press and hold the **(SET)** and **(RESET)** buttons down at the same time for 2s. Press the **(SET)** button to display the items to be set, and the **(+)** and **(-)** buttons, set the details. To save setting for each setting menu, press the **(SET)** button when the End screen is displayed.

The underlined setting parameters are the initial value.

Set-up menu 1: Basic settings (set phase wire system, display pattern, Using VT/direct input, CT primary current, etc.)

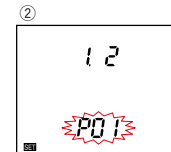
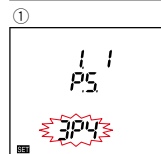
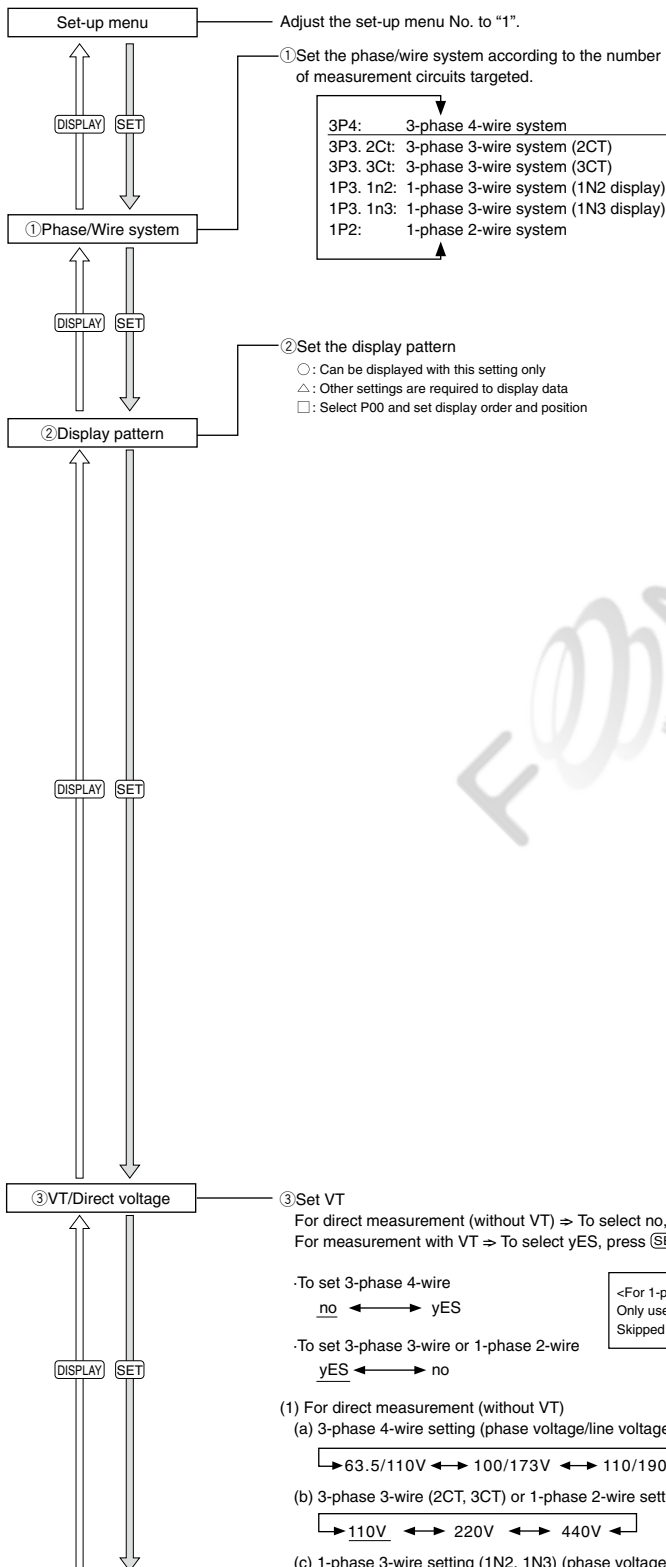

(1) When set to 3-phase 4-wire system

Display Pattern	Additional Screen *Note																						
	Current	N Phase Current	Current demand	N Phase Current demand	Voltage	Active Power	Power Factor	Apparent Power	Frequency	Active Energy (Exported)	Reactive Energy (Imported lag)	Apparent Energy	Active Energy (Exported)	Reactive Energy (Imported)	Apparent Energy (Special)	Periodic Active Energy	Rolling Demand	Harmonic Current/Voltage	Unbalance Rate	Contact Input/output status	Operating Time	CO ₂ Equivalent	
P01	○	○	○	○	○	○	○	○	○	○	○	○	○	○	○	△	△	△	△	△	△	△	△
P02	○	○	○	○	○	○	○	○	○	○	○	○	○	○	○	△	△	△	△	△	△	△	△
P03	□	□	□	□	□	□	□	□	□	□	□	□	□	□	△	△	△	△	△	△	△	△	△

(2) When set to other than 3-phase 4-wire system
*For 1-phase 2-wire system, P02 is not selectable.

Display Pattern	Additional Screen *Note																					
	Current	Current demand	Voltage	Active Power	Power Factor	Apparent Power	Frequency	Active Energy (Exported)	Reactive Energy (Imported)	Apparent Energy (Imported lag)	Apparent Energy	Active Energy (Exported)	Reactive Energy (Imported)	Apparent Energy (Special)	Periodic Active Energy	Rolling Demand	Harmonic Current/Voltage	Unbalance Rate	Contact Input/output Status	Operating Time	CO ₂ Equivalent	
P01	○	○	○	○	○	○	○	○	○	○	○	○	○	○	△	△	△	△	△	△	△	△
P02	○	○	○	○	○	○	○	○	○	○	○	○	○	○	△	△	△	△	△	△	△	△
P03	□	□	□	□	□	□	□	□	□	□	□	□	□	△	△	△	△	△	△	△	△	△

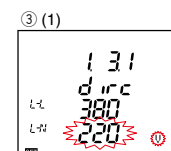
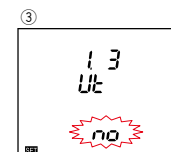



③ VT/Direct voltage

(2) For measurement with VT
 <Secondary voltage settings>
 (a) 3-phase 4-wire setting (phase voltage)
 63.5V ↔ 100V ↔ 110V ↔ 115V ↔ 120V
 (b) 3-phase 3-wire (2CT, 3CT) or 1-phase 2-wire setting (line voltage)
 100V ↔ 110V ↔ 220V

<Set primary voltage>
 The setting ranges from 60V to 750,000V (setting unit: V)
 Factory default settings
 3-phase 4-wire: 200V (phase voltage)
 3-phase 3-wire; 1-phase 2-wire: 10,000V (line voltage)

④ CT current

④ Set CT.
 Set the primary and secondary currents of the CT to be combined.
 <Set secondary current>
 1A ↔ 5A
 <Set primary current>
 The setting ranges from 1.0A to 30,000.0A (setting unit: A)
 Factory default setting: 5.0A

⑤ Frequency

⑤ Set frequency.
 50Hz ↔ 60Hz
 Notes1. Analog output scale will also change.

⑥ Rolling demand time limit

⑥ Set the rolling demand interval time limit (Only ME96SSHB-MB and ME96SSRB-MB).
 (1) Interval time limit

Setting range	Setting interval
1 - 15 - 60 (min)	1min

 (2) Sub-interval time limit

Setting range	Setting interval
1 - 60 (min)	1min

⑦ Current demand time limit

⑦ Set the demand current time limit.

0 s	40 s	3 min	7 min	15 min
10 s	50 s	4 min	8 min	20 min
20 s	1 min	5 min	9 min	25 min
30 s	2 min	6 min	10 min	30 min

Set-up menu

Select another set-up menu or finish set-up.

■ To continue to set-up
 Select the menu No.
 using the (+) or (-) button.



■ To finish set-up
 Press the (+) or (-) button
 to display the End screen,
 then press the (SET) button
 to save the settings.

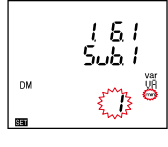
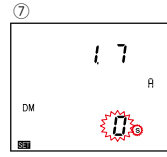
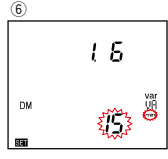
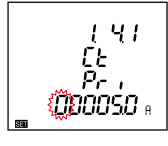
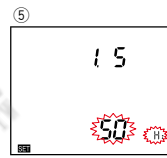
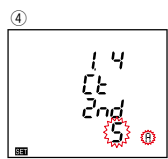
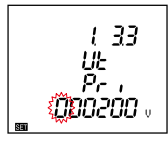
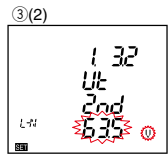

Set-up menu 2: MODBUS RTU Communication settings
 (When ME-0040C-SS96 and ME-0000MT-SS96 are not installed)

Set-up menu

Adjust the set-up menu No. to "2".

① MODBUS RTU communication address

① Set MODBUS RTU communication address
 Possible address settings: 1-255

② MODBUS RTU Baud rate

② Set the MODBUS RTU communication baud rate.

2400bps
4800bps
9600bps
19.2kbps
38.4kbps

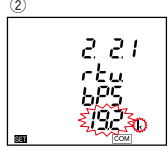
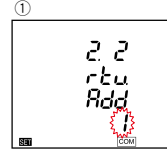

Operating Instructions

<Continued from previous page>

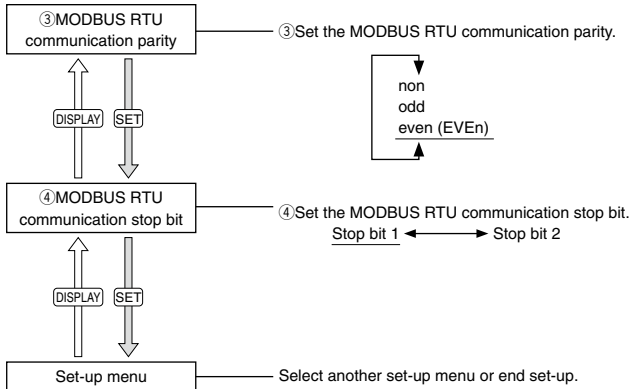

■ To continue to set-up
Select the menu No. using the (+) or (-) button.



■ To finish set-up
Press the (+) or (-) button to display the End screen, then press the (SET) button to save settings.

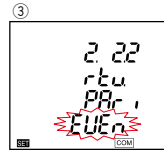

Set-up menu 2: CC-Link Communication settings (when ME-0040C-SS96 is installed)

* Only for ME96SSHB-MB or ME96SSRB-MB, it is applicable.

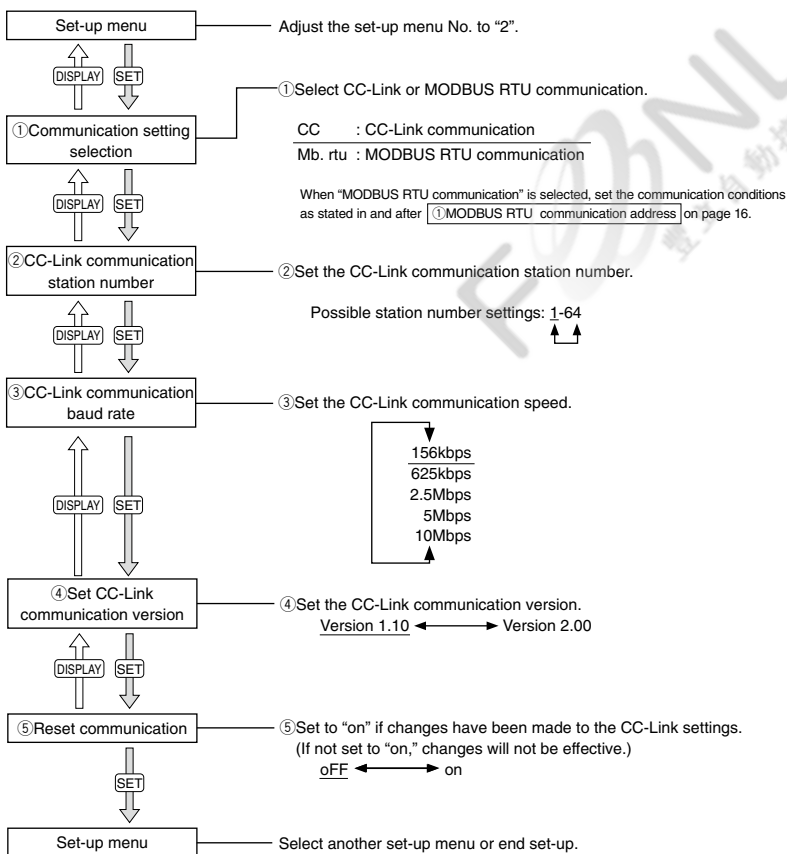

■ To continue to set-up
Select the menu No. using the (+) or (-) button.



■ To finish set-up
Press the (+) or (-) button to display the End screen, then press the (SET) button to save settings.

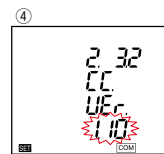
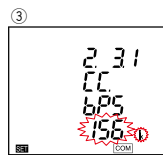
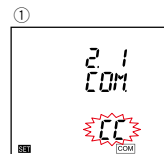

Set-up menu 2: MODBUS TCP Communication settings (when ME-0000MT-SS96 is installed)

* Only for ME96SSHB-MB or ME96SSRB-MB, it is applicable.

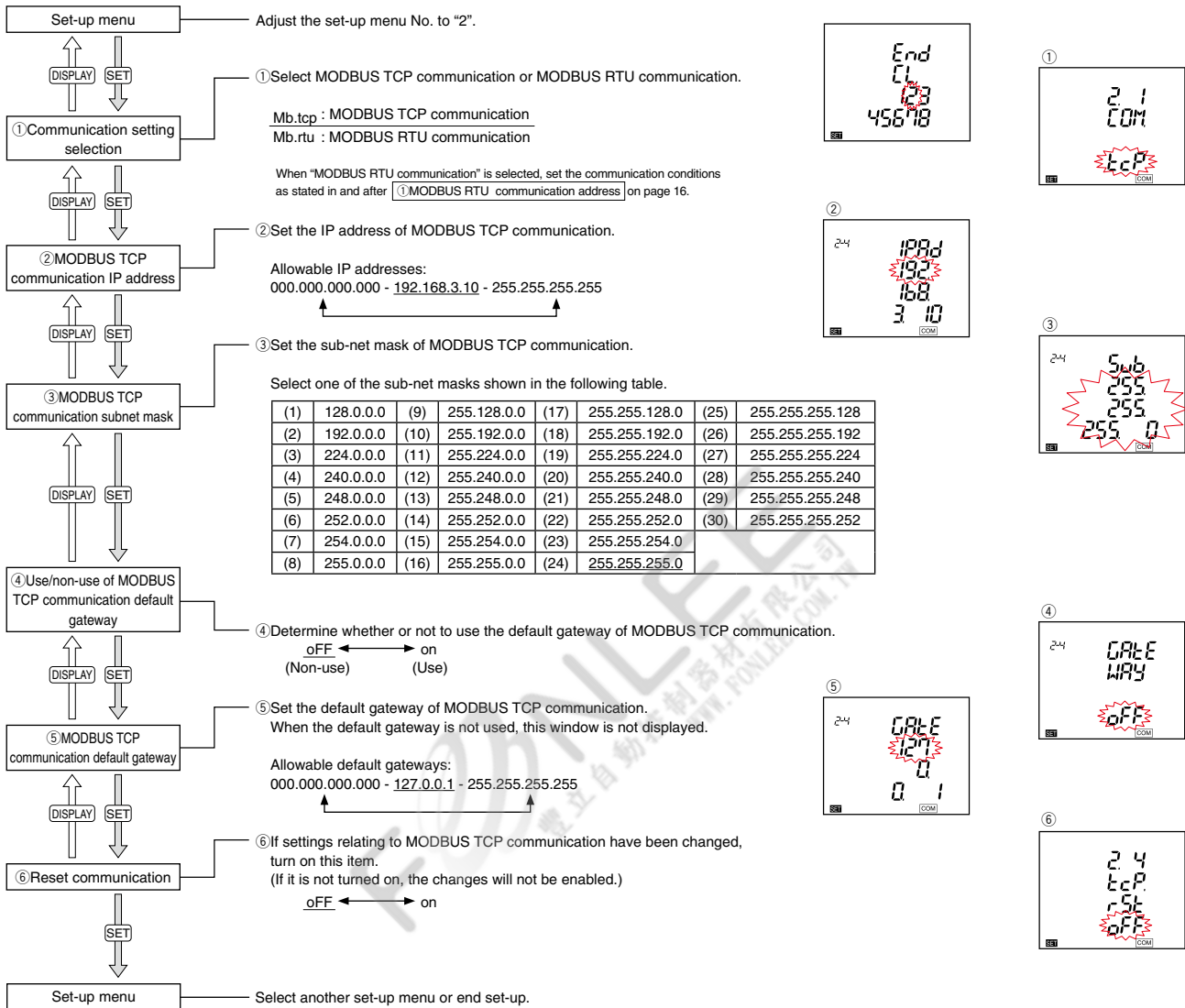

■ To continue to set-up
 Select the menu No. using the (+) or (-) button.



■ To finish set-up
 Press the (+) or (-) button to display the End screen, then press the (SET) button to save settings.



Operating Instructions

Set-up menu 3: Display settings (active energy, harmonics measurement, etc.)

Set-up menu — Adjust the set-up menu No. to "3".

① Active/Reactive energy measurement method — ① Set the display combination for imported/exported and lag/lead of active/reactive energy and the measurement method for reactive energy. (ME96SSHB-MB, ME96SSRB-MB only).

Combinations (set value)	Display combinations						Reactive energy measurement method
	Wh		varh				
	Imported	Exported	Imported		Exported		
			Lag	Lead	Lag	Lead	
I	<input type="radio"/>		<input type="radio"/>				2 Quadrants Measurement
II	<input type="radio"/>			<input type="radio"/>			
III	<input type="radio"/>	<input type="radio"/>	<input type="radio"/>			<input type="radio"/>	4 Quadrants Measurement
IV	<input type="radio"/>	<input type="radio"/>	<input type="radio"/>	<input type="radio"/>	<input type="radio"/>	<input type="radio"/>	

Combinations I, II ⇒ Suitable for measurement in facilities not equipped with in-house generators, and measuring reactive power of capacitor load, where power factor is around zero generally.
 Combinations III, IV ⇒ Suitable for measurements in facilities equipped with in-house generators.

<Example display screens>

Combination I: in : Imported
 Combination II: out : Exported
 Combination III: LEAD : varh (lead)
 Combination IV: LAG : varh (lag)

② Harmonic display — ② Set whether to display the harmonic measured value.

on ←→ off
 (Display) (Not display)

When you set to "on (Display)", harmonic measured values are displayed on the additional screen of display pattern.

③ Unbalance rate display — ③ Set whether to display unbalance rate.

on ←→ off
 (Display) (Not display)

When you set to "on (Display)", voltage/current unbalance rate can be displayed on the additional screen of display pattern.
 Note. For 1-phase 2-wire system, this setting is skipped.

Set-up menu — Select another set-up menu or end set-up

■ To continue to set-up
 Select the menu No. using the (+) or (-) button.

■ To finish set-up
 Press the (+) or (-) button to display the End screen, then press the (SET) button to save settings.

Set-up menu 6: Built-in logging settings

* Only for ME96SSHB-MB, ME96SSRB-MB, it is applicable.

Set-up menu — Adjust the set-up menu No. to "6". (See the drawing on the right)

① Optional selection — Select analog output, built-in logging, or optional logging.

Ao ←→ PLUG ←→ built
 (Analog output) (Optional logging) (Built-in logging)

The explanation here is about built-in logging settings.
 For the analog output settings, refer to Set-up menu 6: Analog output setting.
 For the optional logging settings, refer to Set-up menu 6: Logging setting.
 Note. When ME-4210-SS96 or ME-0000BU-SS96 of optional module is not installed, this setting is skipped.

② Built-in logging Data clear — Clears logging data stored in the main body

no ←→ yES
 (Not clear) (Clear)

When yES (Clear) is selected above, the confirmation screen appears to ask whether or not to clear data.

no ←→ yES
 (Not clear) (Clear)



③ Built-in logging
Use/non-use

Sets whether or not to use the built-in logging function.

DISPLAY SET

on ←————→ off
(Use) (Non-use)



④ Built-in logging
Element patterns

Sets a logging element pattern to choose data that are internally logged.

Patterns usable for setting: → LP00 ↔ LP01 ↔ LP02 ←

By selecting LP00, you can freely choose logging elements.

Logging element patterns for LP01 & LP02 are defined as in the table below.

Detailed data are recorded in an interval that is shorter than that of 1-hour data.

Logging cycle of the detailed data is set in [⑤ Built-in logging period].

Phase wiring type setting: 3-phase 4-wire system

Logging element pattern	LP01	LP02
Data 1 (integrated value)	Wh imported	Wh imported
Data 2 (integrated value)	Wh exported	Wh exported
Data 3 (integrated value)	varh imported (LAG)	varh imported (LAG)
Data 4 (integrated value)	varh imported (LEAD)	varh imported (LEAD)
Data 5 (integrated value)	VAh	VAh
Data 1	W (total) present value	W (total) present value
Data 2	PF (total) present value	PF (total) present value
Data 3	Hz (present value)	Hz (present value)
Data 4	var (total) present value	A (avg) present value
Data 5	VA (total) present value	V (line voltage) (avg) present value
Data 6	A (avg) present value	A1 present value
Data 7	V (line voltage) (avg) present value	A2 present value
Data 8	DW (last value)	A3 present value
Data 9	Dvar (last value)	AN present value
Data 10	DVA (last value)	V12 present value
Data 11	DW (peak value)	V23 present value
Data 12	Dvar (peak value)	V31 present value
Data 13	DVA (peak value)	V1N present value
Data 14	A1 Harmonic present value (total)	V2N present value
Data 15	V1N Harmonic voltage phase voltage distortion ratio (total)	V3N present value



DISPLAY SET

Setting of phase wiring system: 3-phase 3-wire_2CT, 3-phase 3-wire_3CT, 1-phase 3-wire system

Logging element pattern	LP01	LP02
Data 1 (integrated value)	Wh imported	Wh imported
Data 2 (integrated value)	Wh exported	Wh exported
Data 3 (integrated value)	varh imported (LAG)	varh imported (LAG)
Data 4 (integrated value)	varh imported (LEAD)	varh imported (LEAD)
Data 5 (integrated value)	VAh	VAh
Data 1	W (total) present value	W (total) present value
Data 2	PF (total) present value	PF (total) present value
Data 3	Hz (present value)	Hz (present value)
Data 4	var (total) present value	A (avg) present value
Data 5	VA (total) present value	V (line voltage) (avg) present value
Data 6	A (avg) present value	A1 present value
Data 7	V (line voltage) (avg) present value	A2 present value
Data 8	DW (last value)	A3 present value
Data 9	Dvar (last value)	—
Data 10	DVA (last value)	V12 present value
Data 11	DW (peak value)	V23 present value
Data 12	Dvar (peak value)	V31 present value
Data 13	DVA (peak value)	—
Data 14	A1 Harmonic present value (total)	—
Data 15	V12 Harmonic voltage phase voltage distortion ratio (total)	—

Setting of phase wiring system: 1-phase 2-wire system

Logging element pattern	LP01	LP02
Data 1 (integrated value)	Wh imported	Wh imported
Data 2 (integrated value)	Wh exported	Wh exported
Data 3 (integrated value)	varh imported (LAG)	varh imported (LAG)
Data 4 (integrated value)	varh imported (LEAD)	varh imported (LEAD)
Data 5 (integrated value)	VAh	VAh
Data 1	W (total) present value	W (total) present value
Data 2	PF (total) present value	PF (total) present value
Data 3	Hz (present value)	Hz (present value)
Data 4	var (total) present value	A (avg) present value
Data 5	VA (total) present value	V (line voltage) (avg) present value
Data 6	A (avg) present value	A1 present value
Data 7	V (line voltage) (avg) present value	—
Data 8	DW (last value)	—
Data 9	Dvar (last value)	—
Data 10	DVA (last value)	V12 present value
Data 11	DW (peak value)	—
Data 12	Dvar (peak value)	—
Data 13	DVA (peak value)	—
Data 14	A1 Harmonic present value (total)	—
Data 15	V12 Harmonic voltage phase voltage distortion ratio (total)	—

Operating Instructions

<Continued from previous page>

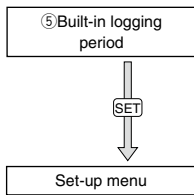

③ Use this to set the cycle in which detailed data of the built-in logging element pattern "LP01" or "LP02" are logged.

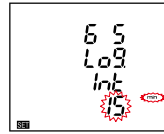
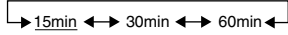

According to "3.1 Set-up Flow", either exit from setting or continue setting in any other set-up menu.

Set-up menu 6: Analog output setting (only when ME-4210-SS96B is installed)

* Only for ME96SSHB-MB or ME96SSRB-MB, it is applicable.

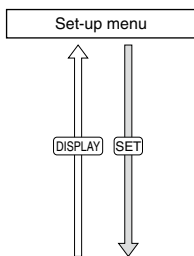

Adjust the set-up menu No. to "6".

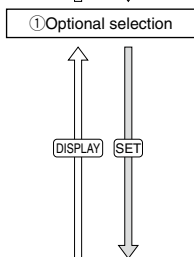

Select "Analog output" or "Built-in logging".

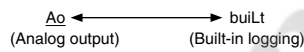

The explanation here is about analog output setting.

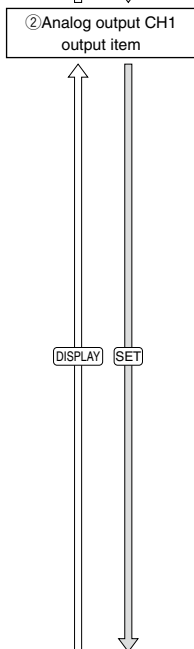
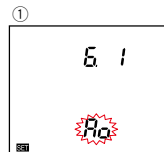

② Set the output item for "analog output CH1".
Select the measured item to be output from the table below.

When 3-phase 4-wire system has been selected

3-phase 4-wire		
non	V ₁₂	PF ₁
A ₁	V ₂₃	PF ₂
A ₂	V ₃₁	PF ₃
A ₃	V _{AVG} (L-L)	PF _Σ (CH4)
A _N	W ₁	Hz
A _{AVG} (CH1)	W ₂	Harmonic A ₁
Demand A ₁	W ₃	Harmonic A ₂
Demand A ₂	W _Σ (CH3)	Harmonic A ₃
Demand A ₃	var ₁	Harmonic A _N
Demand A _N	var ₂	Harmonic V _{1N}
Demand A _{AVG}	var ₃	Harmonic V _{2N}
V _{1N}	var _Σ	Harmonic V _{3N}
V _{2N}	VA ₁	
V _{3N}	VA ₂	
V _{AVG} (L-N) (CH2)	VA ₃	
	VA _Σ	

AVG: Average value, Σ: Total RMS value

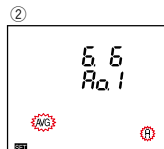

- Notes 1. The same measurement items can be set for all channels.
- Notes 2. Measurement items not included in the selected display pattern can also be chosen.
- Notes 3. Channels set to "non" will have minimum output (4mA). Additionally, set-up will proceed to the next channel.
- Notes 4. Underlined specifications are factory default settings of measurement items allocated to each channel.
- Notes 5. Harmonic current is output at the scale of 0-60% (with respect to rated value) of the total effective value. Harmonic voltage is output at the scale of 0-20% of the total distortion ratio.



③ Analog output CH1 detailed settings

③ Set the details for "analog output CH1."
(The following settings can be made separately from the measurement items included in the display pattern.)

(1) If analog output is selected for current, demand current, voltage, power, reactive power, power factor (set-up menu: 6.6.1)

Output item	Setting range
A Demand A	CT primary current value (value set for [set-up menu 1.4.1 primary current setting]) ← SP. (special primary current value)
V	+10 steps (approx. 250%) ±0 steps (100%: Standard value) -18 steps (approx. 20%)
W var	+3 steps (approx. 120%) ±0 steps (100%: Standard value) -18 steps (approx. 20%)
PF	-0.5-1-0.5 ↔ -0-1-0

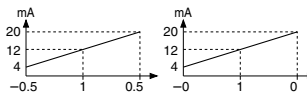

(2) If analog output is selected for current, demand current, power (set-up menu: 6.6.2)

Output item	Setting range
A Demand A	+3 steps (approx. 120%) ±0 steps (100%: instrument rating) -10 steps (approx. 40%)
W	Positive-only ↔ Positive/Negative

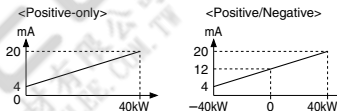

③(1)

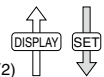
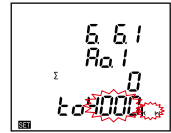
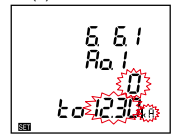

③(2)

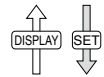
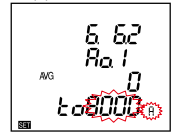

To next channel settings

④ Analog output CH2-4 output item

④ Set the output item for "analog output CH2-4."

The setting procedure is the same as that of [① Analog output CH1 output item].

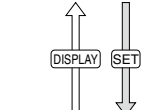

⑤ Set the details for "analog output CH2-4."

The setting procedure is the same as that of [② Analog output CH1 detailed settings].

⑤ Analog output CH2-4 detailed settings

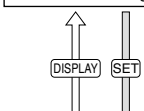

⑥ Set the upper limit for analog output (same for all channels).

Setting	Explanation
oFF (no limit)	Output to +5% of upper limit and -5% of lower limit (with respect to span value)
on (limit)	Output to +1% of upper limit and -1% of lower limit (with respect to span value)

⑥



Note: Skip this setting when the analog output of all channel output items is set to "non."

⑥ Analog output limit

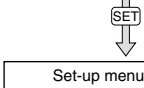

Select another set-up menu or end set-up.

■ To continue to set-up
Select the menu
No. using the (+) or (-) button.



■ To finish set-up
Press the (+) or (-) button
to display the End screen,
then press the (SET) button
to save settings.

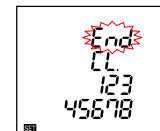

Operating Instructions

Set-up menu 6: Logging setting (only when ME-0000BU-SS96 is installed)

* Only for ME96SSHB-MB or ME96SSRB-MB, it is applicable.

Set-up menu — Adjust the set-up menu No. to "6".

↑ DISPLAY ↓ SET

① Optional selection — ① Select "optional logging" or "built-in logging"

PLUG ← (Optional logging) → built (Built-in logging)

The explanation here is about optional logging setting.

↑ DISPLAY ↓ SET

② Logging ID — ② Set the ID number of the optional logging unit.

Allowable IDs : 001 ~ 255

↑ ↓

When an ID number has been set for the installed optional logging unit, the value is displayed as the default.

Notes: If the SD memory card contains data with the same logging ID, the data may be overwritten.
When the data of more than one optional logging unit are collected in one SD memory card, set the logging ID without fail.

↑ DISPLAY ↓ SET

③ Logging data clear — ③ Clear the data stored in the optional logging unit.

no ← (Not clear) → yES (Clear)

↑ DISPLAY ↓ SET

④ Logging element pattern — ④ Set the logging element pattern to select the data to be logged.
If the logging data is not cleared, the logging element pattern cannot be set.

Allowable patterns : LP01 ↔ LP02 ↔ LP00

When the pattern is set to LP00, any logging elements can be selected. For the details of LP00 setting, see the instruction manual. The logging element patterns of LP01 and LP02 are defined as shown below. Detailed data is recorded at a shorter interval than that of 1-hour data. The detailed data logging interval can be set in ⑤ "Detailed data logging interval."

Phase wire system setting: For 3-phase 4-wire

Logging element pattern	LP01		LP02	
	Detailed data	1-hour data	Detailed data	1-hour data
Data 1	Wh imported	Wh imported	Wh imported	Wh imported
Data 2	varh imported (lag)	Wh exported	A _{AVG}	Wh exported
Data 3	VAh	varh imported (lag)	V _{AVG} (L-L)	varh imported (lag)
Data 4	DW (present value)	varh imported (lead)	W _±	varh imported (lead)
Data 5	Dvar (present value)	VAh	PF _±	VAh
Data 6	DVA (present value)	None	Hz	None

↑ DISPLAY ↓ SET

⑤ Detailed data logging interval — ⑤ Set the interval of logging the detailed data in the logging element pattern LP01 or LP02.
If the logging data is not cleared, the detailed data logging interval cannot be changed.

→ 1min ↔ 5min ↔ 10min ↔ 15min ↔ 30min ←

↓ SET

Set-up menu — Select another set-up menu or end set-up.





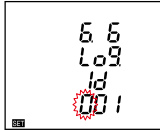

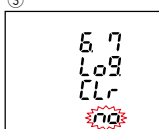

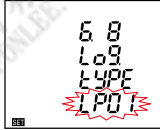

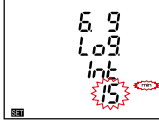



■ To continue to set-up
Select the menu No. using the (+) or (-) button.



■ To finish set-up
Press the (+) or (-) button to display the End screen, then press the (SET) button to save settings.



Operation (for ME96SSH-B-MB)

● Display Change

Press **[DISPLAY]**, the measurement display switches over.
When the **[DISPLAY]** and **[+/-]** buttons are held down for 2 seconds or more, the display will change in reverse order.

Example of display switching (Phase wiring system: 3P4W, Display pattern: P01, No additional screen)

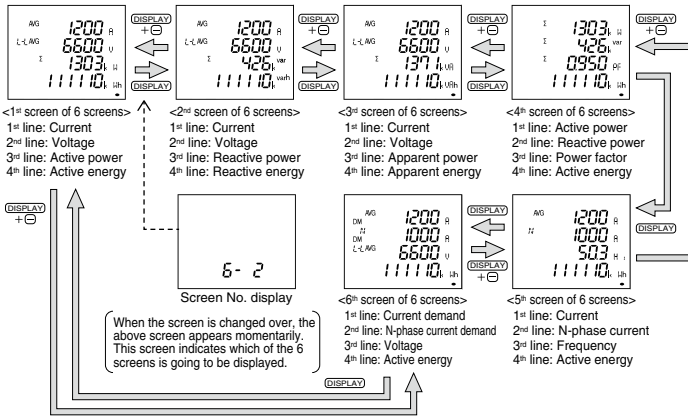

● Changing Phases

Press **[PHASE]**, the current phase and the voltage phase switches over.

Example of display switching (Phase wiring system: 3P4W)

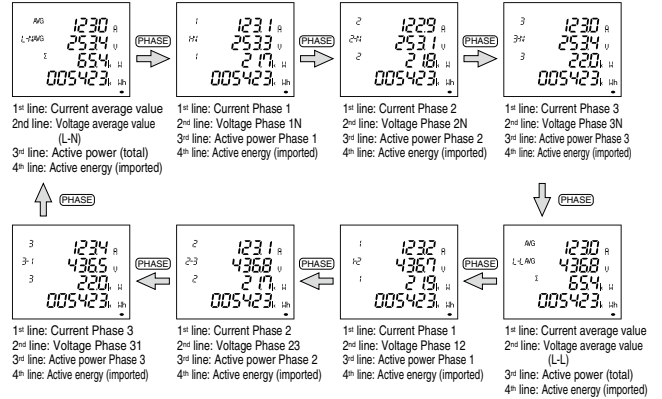

● Maximum/Minimum Display Values

Press the **[MAX/MIN]** button to change to the maximum and minimum values of the display screen. Press it again to return to the current value display screen.

● Reset Maximum/Minimum Values

Press the **[RESET]** button for 2s to reset the maximum/minimum values of the measurement items displayed. The maximum/minimum values will become the current values.

Press the **[RESET]** and **[+]** buttons simultaneously for 2s to reset all maximum/minimum values. The maximum/minimum values will become the current values.

Example of display switching between the current value display screen and MAX/MIN value display screen

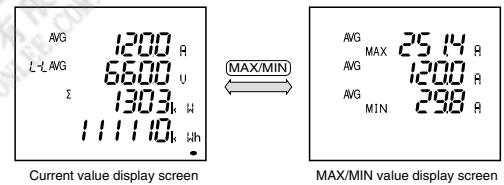

● Displaying Active energy/Reactive energy/Apparent energy

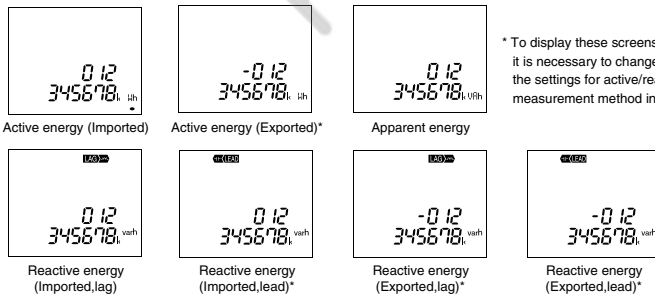

Change the unit (M, k, none) or increase the digits in the bottom display for power used/reactive power used/apparent power used/time-based power used to check the lower/higher-order digits. Push the **[+]** and **[-]** buttons simultaneously for 2s to switch between screens.

Active energy (imported): Example of switching 012, 345, 678, 901, 234, 567Wh

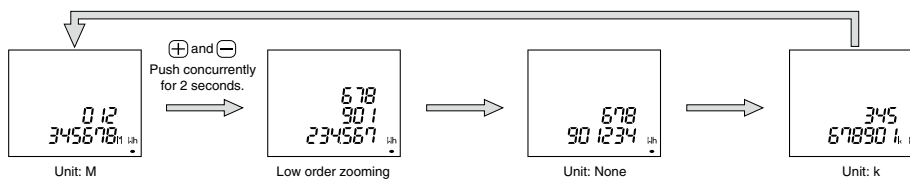

● Reset Active energy/Reactive energy/Apparent energy

Press the **[SET]**, **[RESET]** and **[PHASE]** buttons simultaneously for 2s to reset all of the following together: active energy/reactive energy/apparent energy (this operation only works on the current value display screen).

Operating Instructions

● Changing Upper/Lower Limits for Alarm Activation and Cancellation

When measurement values exceed the upper/lower limit values that have been set, an alarm activates and the screen begins to blink.

● During Alarm Generation

Alarm condition: When a measured value exceeds the alarm value setting, the screen begins to flash and the alarm contact closes.

Alarm cancelled: When the alarm is cancelled, the screen stops flashing and the alarm contact opens.

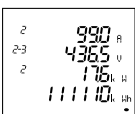
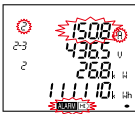
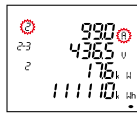
Alarm reset method		Measurement value \geq Upper limit alarm value (or \leq Lower limit alarm value)	Measurement value $<$ Upper limit alarm value (or $>$ Lower limit alarm value)
Automatic (Auto)	Screen		
	Alarm contact	Closed	Open
Manual (Hold)	Screen		
	Alarm contact	Closed	Open

If the item that caused the alarm is displayed on the screen, the digital value, unit (A, V, W, var, PF, HZ, %, DM, THD) and phase (1, 2, 3, N) will be displayed as shown in the table below. If the item is not displayed on the screen, the screen will not flash.

Alarm status	Digital value	Unit	Phase
Alarm activated	Flashing	Flashing	Flashing
Alarm on hold	On	Flashing	Flashing
Alarm cancelled	On	On	On

* Only flashes if the phase that caused the alarm is being displayed.

● Alarm Cancel

The alarm can be reset automatically or manually. The alarm recovery method varies according to the reset method setting.

Alarm reset method	Cancellation method
Automatic (Auto)	The alarm resets automatically when the measurement value returns to within the upper/lower limit set value.
Manual (Hold)	The alarm setting changes to "on hold" even after the measurement value becomes returns to within the upper/lower limit value setting. Once the value returns to within the upper/lower limit value set, perform the following alarm recovery operations. (Note: Alarm recovery operations cannot be carried out from the maximum/minimum value display screen or contact input screen.) <To select item and cancel alarm> When the item that caused the alarm is displayed, press the (RESET) button to deactivate the alarm. (For items with phases such as current and voltage, it is necessary to) press the (RESET) button for each phase to cancel the alarm. <To cancel alarms for all items> To cancel alarms for all items at once (batch), press the (RESET) button for 2s when in operating mode.

● Alarm delay Time

If an alarm delay time has been set, alarm notification begins only when the measurement value exceeds the upper/lower limit alarm value for a period longer than the alarm delay time.

● Harmonic Display

The harmonic effective value, distortion ratio and content ratio can be displayed. To do so, first set the harmonic display (set-up menu: 3.2).

<Harmonic current "total" Display example>

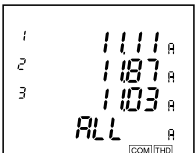

<Harmonic voltage "5th degree" Display example>

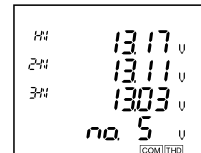

1st line: Side 1 RMS value
2nd line: Side 2 RMS value
3rd line: Side 3 RMS value
4th line: Degree number

<Harmonic current "total" (distortion rate) Display example >

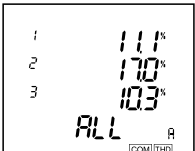

1st line: Side 1 distortion ratio (content rate)
2nd line: Side 2 distortion ratio (content rate)
3rd line: Side 3 distortion ratio (content rate)
4th line: Degree number

Degree	Harmonic current		N-phase harmonic current		Harmonic voltage	
	RMS	Distortion (content) ratio	RMS	Distortion (content) ratio	RMS	Distortion (content) ratio
Harmonic total	○	○	○	—	○	○
1st (fundamental)	○	—	○	—	○	—
3rd, 5th, 7th, 9th, 11th, 13th, 15th, 17th, 19th, 21st, 23rd, 25th, 27th, 29th and 31st	○	○	○	—	○	○

● Changing the Harmonic Degree Display

Press the **(+)** or **(-)** button to change the harmonic degree.

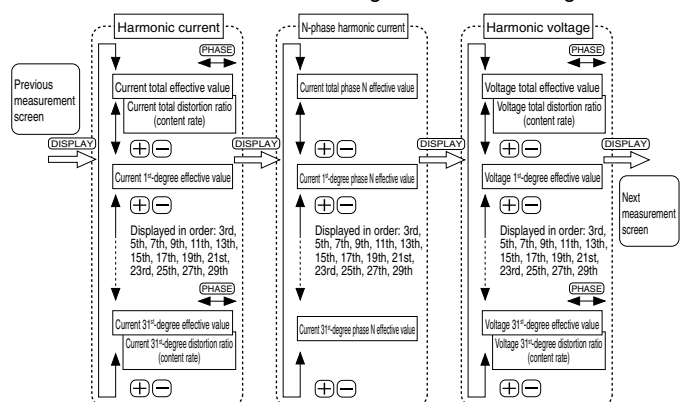



Display Pattern Contents

The items set in display patterns and additional settings will be displayed as explained in the following table.

ME96SSHB-MB/ME96SSRB-MB Screen Display (3-phase 4-wire)

Display pattern	Screen set based on display pattern										
	No.1	No.2	No.3	No.4	No.5	No.6	No.7	No.8	No.9	No.10	
P01	1 st line	A	A	A	W	A	DA				
	2 nd line	V	V	V	var	AN	DAN				
	3 rd line	W	var	VA	PF	H _z	V				
	4 th line	Wh	varh	VAh	Wh	Wh					
P02	1 st line	A1	DA1	V1N	W1	var1	VA1	PF1	A	A	DA
	2 nd line	A2	DA2	V2N	W2	var2	VA2	PF2	H _z	AN	DAN
	3 rd line	A3	DA3	V3N	W3	var3	VA3	PF3	W	var	VA
	4 th line	Aavg	DAavg	VLN avg	W \bar{z}	var \bar{z}	VA \bar{z}	PF \bar{z}	Wh	varh	VAh
P00	1 st line	Free 1	Free 1	Free 1	Free 1						
	2 nd line	Free 1	Free 1	Free 1	Free 1						
	3 rd line	Free 1	Free 1	Free 1	Free 1						
	4 th line	Free 2	Free 2	Free 2	Free 2						

Note 1. Selectable elements for "Free 1" include A, AN, DA, DAN, V, W var, VA, PF, and H_z. Selectable elements for "Free 2" include Wh, -Wh, varh, and VAh.

Display pattern	Additional screens (set in set-up menu Nos. 1, 3, 7 and 8)																						
	No.11	No.12	No.13	No.14	No.15	No.16	No.17	No.18	No.19	No.20	No.21	No.22	No.23	No.24	No.25	No.26	No.27	No.28	No.29	No.30	No.31	No.32	
	Wh	Wh (exported)	varh	varh imported (Lead)	varh exported (Lag)	varh exported (Lead)	VAh	Period Wh1	Period Wh2	Period Wh3	Rolling demand			Harmonic Current	Harmonic Phase N	Harmonic voltage	Unbalance rate	DI status	DO status	Operating time 1	Operating time 2	CO ₂ equivalent	
Common to P00 to P02	1 st line	-	-	-	-	-	-	No.1	No.2	No.3	Peak value			Side 1 value	Side N value	Side 1 value	-	-	-	hour	hour	-	
	2 nd line										Rolling demand, active power Predictive value	Rolling demand, reactive power Predictive value	Rolling demand, apparent power Predictive value	Side 2 value	-	Side 2 value	Aunb	DI	DO	1	2	CO ₂	
	3 rd line	Wh	Wh exported	varh	varh imported (Lead)	varh exported (Lag)	varh exported (Lead)	VAh	Period Wh1	Period Wh2	Period Wh3	Rolling demand, active power Last value	Rolling demand, reactive power Last value	Rolling demand, apparent power Last value	Side 3 value	-	Side 3 value	Vunb	DO No.	DO No.	-	-	Equivalent
	4 th line											Rolling demand, active power Present value	Rolling demand, reactive power Present value	Rolling demand, apparent power Present value	Degree number	Degree number	Degree number	"unb"	Contact status	Contact status	Operating time	Operating time	

Note 2. When an additional screen is added, a screen No. is also added.

Note 3. Wh in the table indicates Wh imported. The varh indicates varh imported (Lag).

Note 4. The additional screen for Wh, varh, and VAh of "P00" is not displayed unless Wh, varh, and VAh are set as the display elements.

ME96SSHB-MB/ME96SSRB-MB Screen Display (3-phase 3-wire, 1-phase 3-wire, 1-phase 2-wire)

Display pattern	Screen set based on display pattern						
	No.1	No.2	No.3	No.4	No.5	No.6	
P01	1 st line	A	A	A	W	A	
	2 nd line	V	V	V	var	DA	
	3 rd line	W	var	VA	PF	H _z	
	4 th line	Wh	varh	VAh	Wh	Wh	
P02	1 st line	A1	DA1	V12	W	A	A
	2 nd line	A2	DA2	V23	var	H _z	V
	3 rd line	A3	DA3	V31	PF	var	VA
	4 th line	Aavg	DAvg	Vavg	Wh	varh	VAh
P00	1 st line	Free 1	Free 1	Free 1	Free 1		
	2 nd line	Free 1	Free 1	Free 1	Free 1		
	3 rd line	Free 1	Free 1	Free 1	Free 1		
	4 th line	Free 2	Free 2	Free 2	Free 2		

Note 1. For 1-phase 2-wire setting, the display pattern P02 cannot be set.

Note 2. Selectable elements for Free 1 include A, DA, V, W, var, VA, PF, and H_z. Selectable elements for Free 2 include Wh, -Wh, varh, and VAh.

Display pattern	Additional screens (set in set-up menu Nos. 1, 3, 7 and 8)																					
	No.7	No.8	No.9	No.10	No.11	No.12	No.13	No.14	No.15	No.16	No.17	No.18	No.19	No.20	No.21	No.22	No.23	No.24	No.25	No.26	No.27	
	Wh	Wh (exported)	varh	varh imported (Lead)	varh exported (Lag)	varh exported (Lead)	VAh	Period Wh1	Period Wh2	Period Wh3	Rolling demand			Harmonic Current	Harmonic voltage	Unbalance rate	DI status	DO status	Operating time 1	Operating time 2	CO ₂ equivalent	
Common to P00 to P02	1 st line	-	-	-	-	-	-	No.1	No.2	No.3	Peak value			Side 1 value	Side 1 value	-	-	-	hour	hour	-	
	2 nd line										Rolling demand, active power Predictive value	Rolling demand, reactive power Predictive value	Rolling demand, apparent power Predictive value	Side 2 value	Side 2 value	Aunb	DI	DO	1	2	CO ₂	
	3 rd line	Wh	Wh exported	varh	varh imported (Lead)	varh exported (Lag)	varh exported (Lead)	VAh	Period Wh1	Period Wh2	Period Wh3	Rolling demand, active power Last value	Rolling demand, reactive power Last value	Rolling demand, apparent power Last value	Side 3 value	Side 3 value	Vunb	DO No.	DO No.	-	-	Equivalent
	4 th line											Rolling demand, active power Present value	Rolling demand, reactive power Present value	Rolling demand, apparent power Present value	Degree number	Degree number	Degree number	"unb"	Contact status	Contact status	Operating time	Operating time

Note 3. When an additional screen is added, a screen No. is also added.

Note 4. Wh in the table indicates Wh imported. The varh indicates varh imported (Lag).

Note 5. The additional screen for Wh, varh, and VAh of "P00" is not displayed unless Wh, varh, and VAh are set as the display elements.

Note 6. For 1-phase 2-wire system, Unbalance rate (No.22) is not displayed.

Operating Instructions

●ME96SSEB-MB Screen Display (3-phase 4-wire)

Display pattern	Screen set based on display pattern										
	No.1	No.2	No.3	No.4	No.5	No.6	No.7	No.8	No.9	No.10	
P01	1 st line	A	A	A	W	A	DA				
	2 nd line	V	V	V	var	AN	DAN				
	3 rd line	W	var	VA	PF	H _z	V				
	4 th line	Wh	varh	VAh	Wh	Wh	Wh				
P02	1 st line	A1	DA1	V1N	W1	var1	VA1	PF1	A	A	DA
	2 nd line	A2	DA2	V2N	W2	var2	VA2	PF2	H _z	AN	DAN
	3 rd line	A3	DA3	V3N	W3	var3	VA3	PF3	W	var	VA
	4 th line	Aavg	DAavg	VLN avg	W Σ	var Σ	VA Σ	PF Σ	Wh	varh	VAh
P00	1 st line	Free 1	Free 1	Free 1	Free 1						
	2 nd line	Free 1	Free 1	Free 1	Free 1						
	3 rd line	Free 1	Free 1	Free 1	Free 1						
	4 th line	Free 2	Free 2	Free 2	Free 2						

Note 1. Selectable elements for "Free 1" include A, AN, DA, DAN, V, W var, VA, PF, and H_z. Selectable elements for "Free 2" include Wh, -Wh, varh, and VAh.

Display pattern	Additional screens (set in set-up menu Nos. 3 and 8)											
	No.11	No.12	No.13	No.14	No.15	No.16	No.17	No.18	No.19	No.20	No.21	No.22
Common to P00 to P02	1 st line	-	-	-	-	-	-	Side 1 value	Side N value	Side 1 value	hour	hour
	2 nd line							Side 2 value		Side 2 value	1	2
	3 rd line	Wh	Wh exported	varh	varh imported (Lead)	varh exported (Lag)	varh exported (Lead)	VAh	Side 3 value	Side 3 value	-	-
	4 th line								Degree number	Degree number	Operating time	Operating time

Note 2. When an additional screen is added, a screen No. is also added.

Note 3. Wh in the table indicates Wh imported. The varh indicates varh imported (Lag).

Note 4. The additional screen for Wh, varh, and VAh of "P00" is not displayed unless Wh, varh, and VAh are set as the display elements.

●ME96SSEB-MB Screen Display (3-phase 3-wire, 1-phase 3-wire, 1-phase 2-wire)

Display pattern	Screen set based on display pattern					
	No.1	No.2	No.3	No.4	No.5	No.6
P01	1 st line	A	A	A	W	A
	2 nd line	V	V	V	var	DA
	3 rd line	W	var	VA	PF	H _z
	4 th line	Wh	varh	VAh	Wh	Wh
P02	1 st line	A1	DA1	V12	W	A
	2 nd line	A2	DA2	V23	var	H _z
	3 rd line	A3	DA3	V31	PF	var
	4 th line	Aavg	DAavg	Vavg	Wh	varh
P00	1 st line	Free 1	Free 1	Free 1	Free 1	
	2 nd line	Free 1	Free 1	Free 1	Free 1	
	3 rd line	Free 1	Free 1	Free 1	Free 1	
	4 th line	Free 2	Free 2	Free 2	Free 2	

Note 1. In the case of 1-phase 2-wire setting, the display pattern P02 cannot be set.

Note 2. Selectable elements for Free 1 include A, DA, V, W, var, VA, PF, and H_z. Selectable elements for Free 2 include Wh, -Wh, varh, and VAh.

Display pattern	Additional screens (set in set-up menu Nos. 3 and 8)										
	No.7	No.8	No.9	No.10	No.11	No.12	No.13	No.14	No.15	No.16	No.17
Common to P00 to P02	1 st line	-	-	-	-	-	-	Side 1 value	Side 1 value	hour	hour
	2 nd line							Side 2 value	Side 2 value	1	2
	3 rd line	Wh	Wh exported	varh	varh imported (Lead)	varh exported (Lag)	varh exported (Lead)	VAh	Side 3 value	Side 3 value	-
	4 th line								Degree number	Degree number	Operating time

Note 3. When an additional screen is added, a screen No. is also added.

Note 4. Wh in the table indicates Wh imported. The varh indicates varh imported (Lag).

Note 5. The additional screen for Wh, varh, and VAh of "P00" is not displayed unless Wh, varh, and VAh are set as the display elements.

●Phase/Wire Displays

The phase/wire system will be displayed as shown in the following table and is common for all models.

Phase/Wire settings		1P2W	1P3W(1N2)	1P3W(1N3)	3P3W
Top phase display	1	None	1	1	1
	2	None	N	N	2
	3	None	2	3	3
Voltage	12	None	1N	1N	12
	23	None	2N	3N	23
	31	None	12	13	31

External Dimensions/Installation/Connections

Dimensions

ME96SSH-B-MB, ME96SSRB-MB

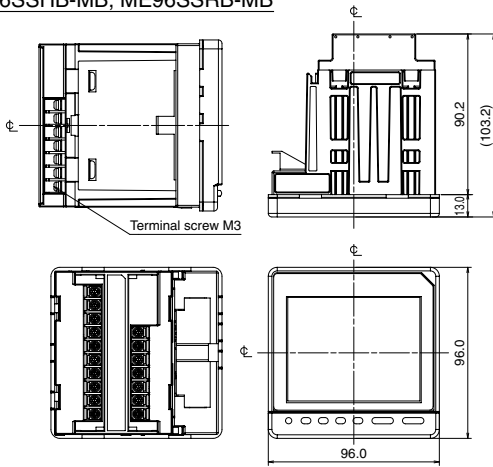

ME96SSEB-MB

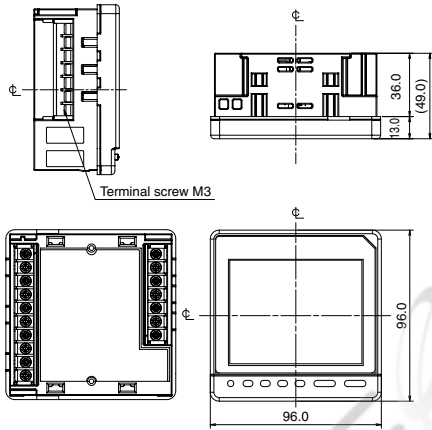

Optional Plug-in Module : ME-4210-SS96B, ME-0040C-SS96, ME-0052-SS96

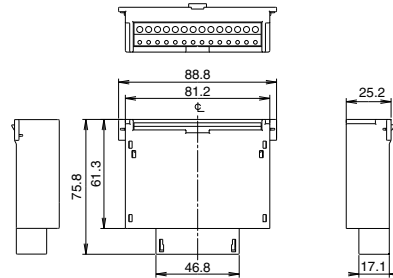

Optional Plug-in Module : ME-0000BU-SS96

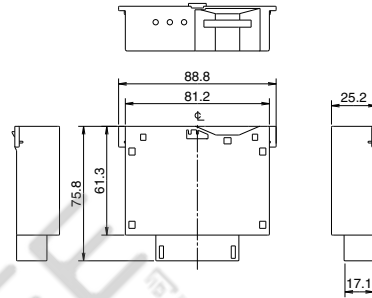

Optional Plug-in Module : ME-0000MT-SS96

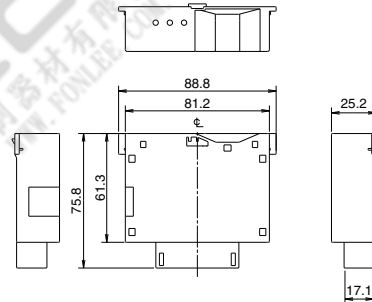

Mounting

1 Dimension of panel

Panel hole dimensions are as shown in the following figure. It can be attached to a panel with thickness of 1.6 to 4.0mm.

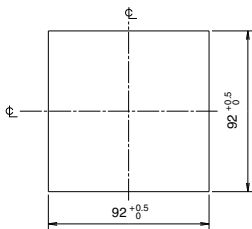

2 View Angle

The contrast of the display changes at view angle. Mount it at the position that is easy to see.

ME96SSEB-MB

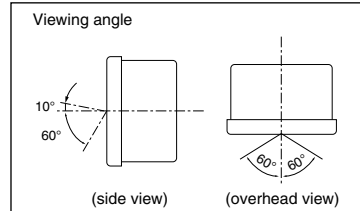

ME96SSH-B-MB/ME96SSRB-MB

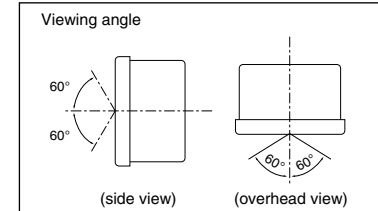

3 Attachment

For attachment of the basic device into the panel hole, attach according to the following procedure.

- ① The attachment lug is installed in two holes of the top and bottom of the basic device.
- ② Tighten the screws of the lug, and fix onto the panel.

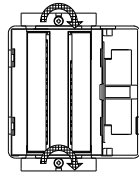
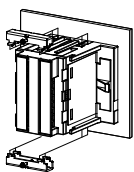

Note

To prevent damage to the panel and screws, do not overtighten the screws.
The recommended torque for this product is 0.3 N·m to 0.5 N·m (about half the normal torque).
Tighten the two screws evenly.

Main unit mounting screws: M3

4 Installing Optional Plug-in Module

When installing the optional plug-in module onto the basic device, install according to the following procedure.

- ① Remove the optional cover.
- ② Attach the optional unit to the main unit.

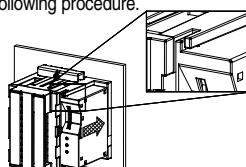
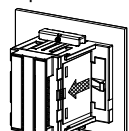

Fit the protruding part of the optional unit into the slot in the main unit.

Wiring

1 Applicable Cable Size

The table on the right describes the applicable wire size.

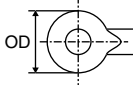
Part	Screw type	Wire specifications	Tightening torque
Product main body (auxiliary power supply, voltage input, current input and MODBUS RTU communication terminals)	M3	<ul style="list-style-type: none"> Use of crimp-style terminals: AWG26 to 14 (2 wires can be connected.) Applicable crimp-style terminal: OD of 6 mm or less, for screw M3 	0.6 to 0.8 N·m
Optional unit terminal (ME-0052-SS96, ME-0040C-SS96, ME-4210-SS96B)	Screwless	<ul style="list-style-type: none"> Single wire and stranded wire: AWG24 to 14 (Rod terminal can be used together with stranded wire.) Wire stripping length: 10 to 11 mm *1: To conform to UL Standard, use in accordance with the following requirements. <ul style="list-style-type: none"> • Single wire and stranded wire: AWG24 to 18 • Use of a bar terminal is not allowed. *2: When using a bar terminal for inserting two wires, select a terminal whose insertion part into the terminal block is 12 to 13 mm long. 	—

2 Wiring

Optional Plug-in Module Terminal

- Remove the wire casing at the end of the wire and solder to the rod terminal.
- With the lever pushed in, insert the wire and then release the lever to connect.

Optional Plug-in Module Terminal

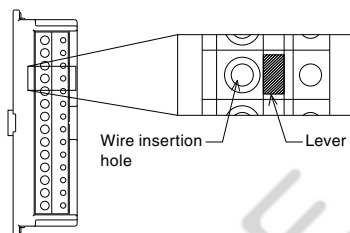

3 Confirmations

After wiring, make sure the following:

- All wiring is connected
- There is no mistake in wiring

Note

Protective sheet

There is a protective sheet covering the LCD screen to prevent scratching during panel installation. Please remove the sheet before using the meter. When removing the sheet, the LCD may turn on due to the static electricity generated. This is not abnormal; the LCD will turn off after a short time.

Installation position

If installing the unit at the panel edge, choose an installation position where there is sufficient space for wiring work.

Optional unit

Turn the auxiliary power supply off before attaching the optional unit. If attached with the power on, the main unit will not recognize the optional unit. To remedy this, turn off/restart the auxiliary power supply or execute the "instrument restart" operation.

Wiring Diagrams

Three phase 4-wire system: Direct input

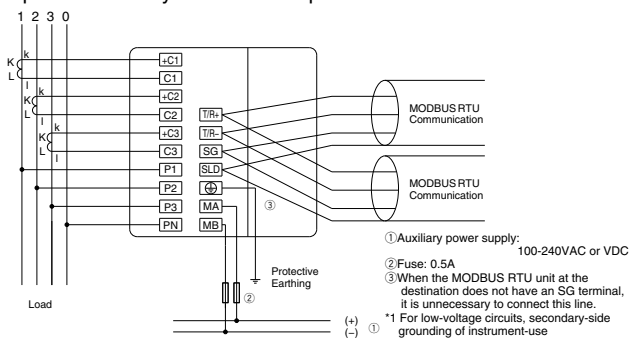

Three phase 4-wire system: With VT

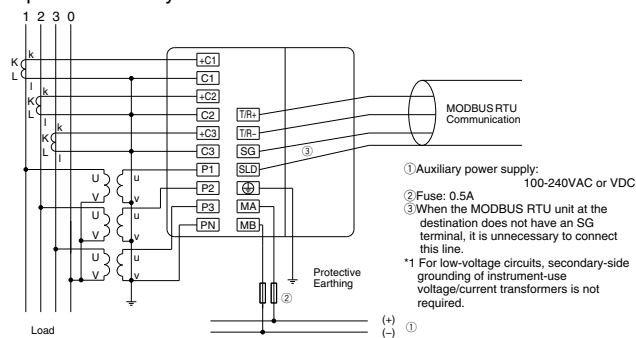

Three phase 3-wire system: Direct input, 2CT

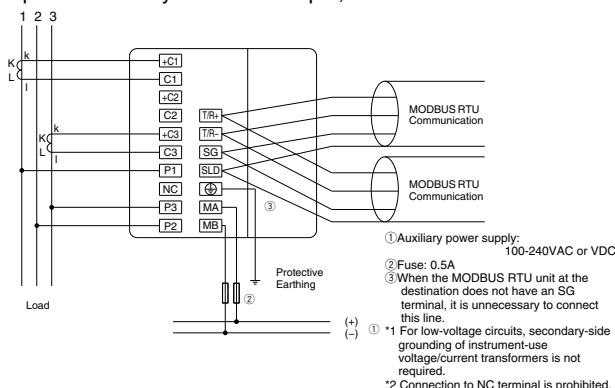

Three phase 3-wire system: With VT, 3CT

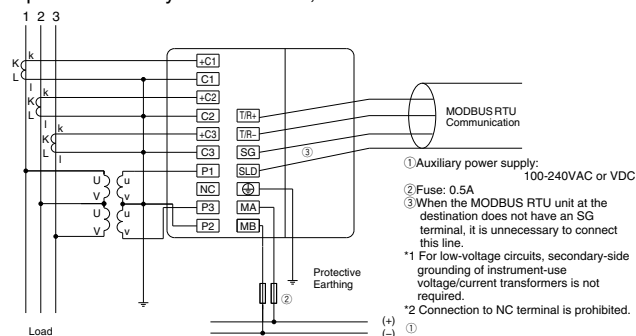

External Dimensions/Installation/Connections

Wiring Diagrams (Continued)

Single phase 3-wire system

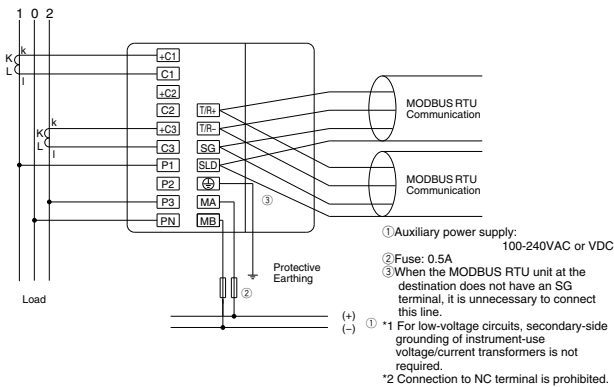

Single phase 2-wire system: With VT

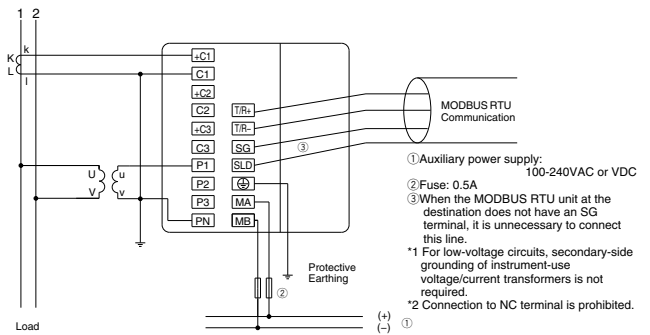

Note

1. The voltage input terminal will vary depending on if it is a 3-phase, 3-wire system or otherwise.
2. VT/CT polarity errors will cause incorrect measurement.
3. Always use the grounding terminal (⊕) in a grounded state. Perform grounding with a grounding resistance of 100Ω or less. Insufficient grounding may cause erroneous operation.
4. Use shielded twisted-pair cables for transmission signal lines.
5. Install 120Ω terminating resistors between terminals "T/R+" and "T/R-" for devices at both ends of MODBUS RTU communication line.
6. Use the thickest possible grounding wire to ensure low impedance.
7. MODBUS RTU transmission signal cables must not be in close proximity or bundled with high-voltage cables.

Optional Plug-in Module: ME-4210-SS96B

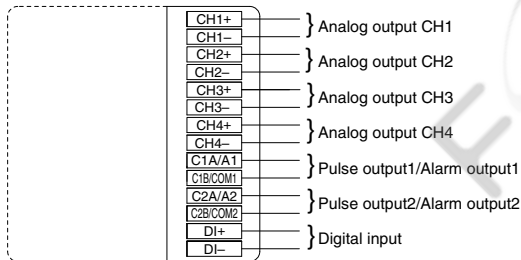

Optional Plug-in Module: ME-0040C-SS96

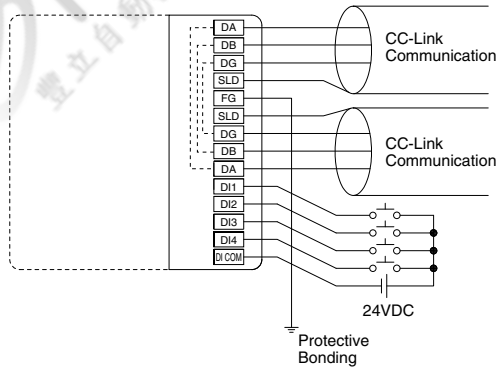

Optional Plug-in Module: ME-0052-SS96

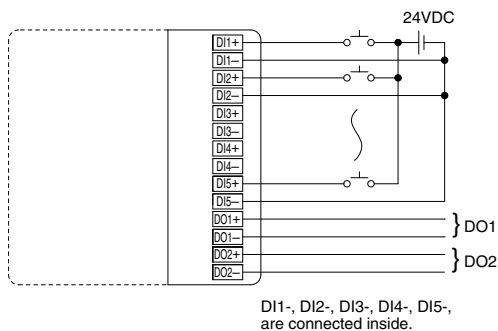

Optional Plug-in Module: ME-0000MT-SS96

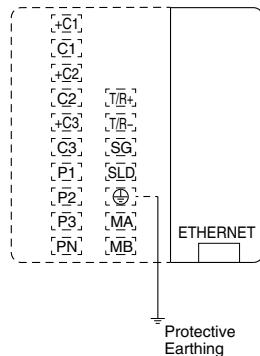

Optional Plug-in Module: ME-0000BU-SS96

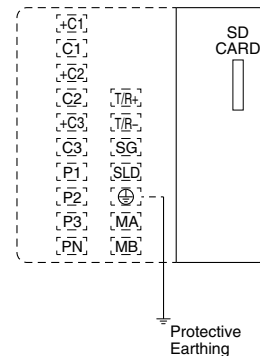

Wiring Diagrams (Continued)

Note

- Pulse output, alarm output, and contact input/output cables must not be in close proximity or bundled with power cables or high-voltage cables. When laid parallel, separate by the distance shown in the following table.

Condition	Distance
Power lines of 600V or less	300mm or more
Other power lines	600mm or more

- Analog output cables must not be in close proximity or bundled with other power cables or input cables (e.g., VT, CT, auxiliary power supply). In addition, to prevent noise, surge and induction, use shielded cables or twisted-pair cables. Make sure that cables are as short as possible.
- There is no insulation between the MODBUS RTU communication portion and the optional module ME-4210-SS96B, ME-0040C-SS96 or ME-0000MT-SS96.
- Use only designated cables when connecting the CC-Link (see communication specifications). CC-Link dedicated cables cannot be used at the same time as CC-Link dedicated high-performance cables. Normal data transmission cannot be guaranteed if used at the same time.
The terminal resistance value varies depending on the type of dedicated cable.
- For cables connecting the CC-Link, connect shielded cables to "SLD" and ground "FG" cables. "SLD" and "FG" cables are connected inside the unit.
- CC-Link transmission lines are small signal circuits: separate from strong electrical circuits by a distance of 10cm or more, or 30cm or more if laid in parallel over a long distance.
Ground the terminal before use.
- For CC-Link transmission, always use dedicated lines and comply with conditions for total wiring distance, distance between stations and terminal resistance values according to the communication speed. Not doing so may prevent normal communication (see the CC-Link Master Unit Operations Manual for information on dedicated lines and wiring conditions).
- The terminal resistance supplied with the CC-Link Master Unit must always be used for the units at both ends of the CC-Link transmission line. If the meter is at the end of the CC-Link transmission line, connect it between the DA and DB terminals.
- Communication errors may occur under the influence of high-frequency noise from other devices in the installation environment during high-speed communication (100 Mbps) via 100BASE-TX connection of MODBUS TCP.
Measures to be taken when the network system is configured to avoid the influence of high-frequency noise are shown below.
 - Wiring connection
 - When laying a twisted pair cable, do not bundle the cable together with any main circuit line or power line or lay it close to such a line.
 - Keep the twisted pair cables in the duct.
 - Communication method
 - Increase the number of communication retries as needed.
 - Replace the hub to be used for connection with that for 10 Mbps, and communicate at a data transmission speed of 10 Mbps.
- Do not connect any terminal or RJ45 connector in the live state.
- Do not insert or remove the SD memory card in the live state.

Rated voltage for each phase/wire system

Phase/Wire	Connection	Rated voltage	Figure
Three phase 4-wire	Star	Max. 277VAC (L-N)/480VAC(L-L)	Figure 1
	Delta	Max. 220VAC (L-L)	Figure 2
Three phase 3-wire	Star	Max. 440VAC (L-L)	Figure 3
	-	Max. 220VAC (L-N)/440VAC(L-L)	Figure 4
Single phase 2-wire*	Delta	Max. 220VAC (L-L)	Figure 5
	Star	Max. 440VAC (L-L)	Figure 6

* The circuit derived from the three-phase 3-wire delta connection and the single-phase 2-wire transformer circuit have the maximum rating of 220 VAC. The circuits derived from the three-phase 4-wire and three-phase 3-wire star connections and single-phase 3-wire connection have the maximum rating of 440 VAC.

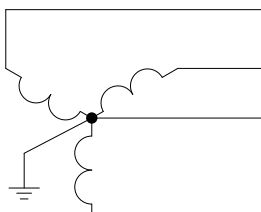

Fig. 1. Three phase 4-wire (star)

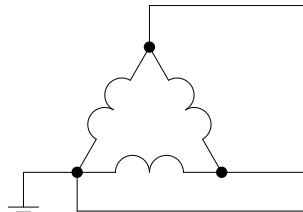

Fig. 2. Three phase 3-wire (delta)

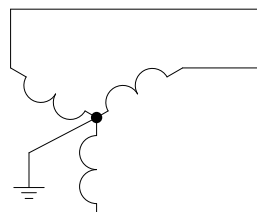

Fig. 3. Three phase 3-wire (star)

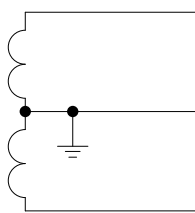

Fig. 4. Single phase 3-wire

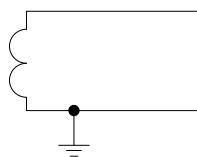

Fig. 5. Single phase 2-wire (delta)

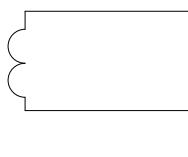

Fig. 6. Single phase 2-wire (star)

Related Products

■ EcoWebServerIII

Mitsubishi Electric Energy-saving Data Collection Server
From visualization to publication of energy data

Simple Set-up

When using the set-up software supplied, power management meters connected to CC-Link and measurement data can be set by mouse and keyboard operations.

Display Measurement Data as Graphs on a Web Browser

The main unit has a built-in web server that allows anyone, anywhere to understand the amount of energy being used in real time via computer without requiring additional software, thereby supporting early detection of energy waste.

Automatic Transmission of Data Collected, Mail Notifications and Contact Output

Users are notified of changes in energy, facilities, etc. via e-mail and alarms. Energy management targets and status monitoring of entire factories and buildings help ensure that problems onsite are detected without fail.

- ◇ PLC data can also be sent to EcoWebServerIII by Ethernet.
- ◇ Data of various sites can be browsed in the head office by utilizing the internal network.

Collection, storage, visualization, publication on the web, analysis and monitoring
All can be realized by one server.

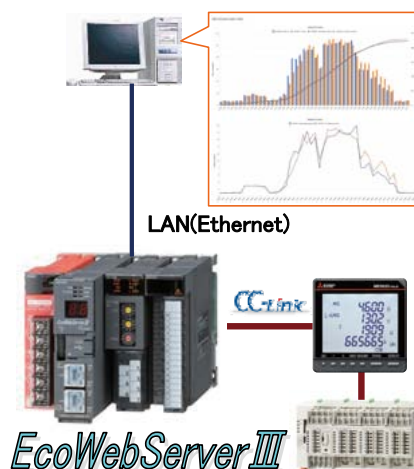

■ EcoMonitorPlus

Energy measuring units helpful in adding units for increased number of measuring circuits and preventive maintenance by simultaneous measurement of electric power and leakage

Phased expansion of energy-saving system

At first, energy-saving measurement can be started on a small scale from a desired place.

The system can be configured by adding units according to the increase of measuring circuits.

Leakage current monitoring

Lineup of basic units for monitoring insulation

Helpful in early detection of equipment problems through accurate leakage current trend monitoring by Ior method

* Ior: Leakage current caused by insulation deterioration (leakage current of resistive component)

Simple management of measurement data with prepared forms and graphs

Data can be collected by the logging unit (SD memory card) without the host application on the PC, etc.

Forms and graphs can be easily prepared by using the spreadsheet software (logging unit utility*).

* The logging unit utility can be downloaded for free from Mitsubishi Electric FA site.

Energy Measuring Unit
EcoMonitorPlus





■ EcoMonitorLight

Energy measuring unit with integrated display for easily realizing the visualization of energy

A three-model line-up: a Three phase 3-wire system designed for users wanting simple power measurements at low cost; and a Three phase 4-wire system designed for users looking for basic power measurements plus something extra (harmonic measurements, alarm monitoring, etc.).

Simple Measurements

The built-in LCD enables easy setting, measurement and display of power used for energy management.

MODBUS RTU (RS-485) Communication as Standard Equipment

Meters come with MODBUS RTU communication as standard equipment, allowing the device to be used as a PLC system, other high-order system, display device (GOT), etc.

Logging/Communication Units for Expanded Measurement Applications

The product line-up also includes logging units/communication units (CC-Link communication unit) that can be incorporated as add-on options, enabling installations that best match to the customer's usage environment.

■ Logging unit: Data measured by the main unit (current, voltage, power, etc.) can be output to an SD memory card in CSV file format, realizing simple data management.

Highly Accurate Measurements and Support Functions

Customer activities are supported through functions such as 250μs high-precision (short-cycle load) measurement, operating time measurement, wiring error detection and test output.

Energy Measuring Unit Eco Monitor Light



FOONLEE

豐立自動控制器材有限公司
www.foonlee.com.tw

Safety Precautions

To ensure safety, read the following items carefully before use and always comply with procedures during use. Special attention should be given to items enclosed in a box and marked "Caution." Additionally, please carefully read the operations manual supplied with the product before use, and ensure that the manual read by the end user as well.

1 Usage Environment and Conditions

Do not use these products under any of the following conditions. Doing so may cause erroneous operation and/or reduced service life.

- Ambient temperature is outside the range of -5°C to +55°C
- Daily average temperature over 35°C
- Relative humidity over 85% RH non-condensing
- Presence of excessive dust, corrosive gas, salt or oil/smoke
- Product is subject to excessive vibration or shock
- Product is in direct contact with rain, water drops or sunlight
- Altitude is above 2,000m
- Excessive external noise
- Pollution level is 2 or higher
- Transient overvoltage is 4,000V or higher
- Presence of metal fragments or conducting substances

2 Installation

Please note the following items regarding installation. To ensure safety, installation is to be performed by a qualified technical electrician.

- Affix the main unit to the panel before use
- The LCD display contrast changes depending on the angle from which it is viewed. Install it in a position that ensures a suitable angle of view.
- Tighten screws using a torque of approx. 0.3-0.5N·m
- To prevent damage to the LCD, take care not to subject the LCD/front of the main unit to shock/impact.

Auxiliary power supply and instrument ratings

Auxiliary power supply		100-240VAC (±15%) 50-60Hz 100-240VDC (-30%, +15%)
Instrument ratings	Voltage	Three phase, 4-wire: Max. 277/480VAC Three phase, 3-wire: Delta connection: Max. 220VAC, Star connection: Max. 440VAC Single phase, 3-wire: Max. 220/440VAC Single phase, 2-wire: Delta connection: Max. 220VAC, Star connection: Max. 440VAC
	Current	5A/1A
	Frequency	50-60Hz (dual use)

3 Connections

See pages 30-32 of this catalog for information regarding connections.

	<ul style="list-style-type: none"> • To ensure safety, connections are to be performed by an electrical engineer qualified in wiring. • Check connection diagrams carefully before performing connections. Incorrect connections may result in VT burnout caused by a VT secondary-side short circuit or high voltage on the CT secondary side, which may lead to device malfunction, fire or electrical shock. • Do not work with live wires; there is a risk of electric shock and exposure to high voltage due to short-circuiting or CT secondary side opening, which may lead to malfunction, fire or electrical shock. • Use electrical wire sizes compatible with the rated current. Use of unsuitable sizes may cause heat generation, which may lead to a fire. • After performing connections, check that no connections have been missed. Missed connections may result in erroneous operation or high voltage on the CT secondary side, which may lead to a fire or electrical shock. • At the time of wiring, an electric wire can be broken by pulling with strong power. (The load of pulling is less than 3-9 N)
---	--

4 Preparations Before Use

- Before use, perform settings such as the VT primary voltage, CT primary current, power scale and demand time limit in accordance with the operations manual supplied with the product; setting errors may cause incorrect measurement/operation.

5 Usage Procedures

- Use the products within the rated range. Using the products outside the rated range may cause erroneous operation or product malfunction.
- Do not use the products for special applications such as nuclear power, aerospace or medical devices/systems.

	<ul style="list-style-type: none"> • Do not make any modifications to the products. Using products after modification may cause a malfunction, electrical shock or fire.
---	---



6 Repairing at Time of Malfunction/Error

- If a product listed in this catalog malfunctions, read the troubleshooting section of the operations manual (detailed version) and confirm the symptoms. If the problem is not listed, please contact a Mitsubishi Electric representative.

7 Maintenance/Inspections

- Wipe away any dust/dirt on the surface of the product with a soft cloth.
- Do not leave chemical cloths, etc. in contact with the product for long periods, and avoid the use of benzene, thinner, etc. when wiping the product surface. Doing so may cause deformation or cause the coating to peel away.
- To ensure correct use for the full service life of the product, please perform the following inspections:
 - ① Check for damage to the product
 - ② Check for display malfunctions (e.g., does not respond to input)
 - ③ Check for loose installation or terminal block wire connections (check regularly once every six months/year) always making sure that power has been turned off beforehand)
 - ④ Check for unusual smell, noise or rise in temperature.

8 Storage

Do not store the product for long periods of time under any of the following conditions. Doing so may lead to a malfunction or reduced service life.

- Ambient temperature outside the range of -25°C to +75°C
- Daily average temperature of more than 35°C
- Relative humidity exceeding 85% RH or condensation present
- Excessive dust, corrosive gas, salt or oil/smoke present
- Product is subject to excessive vibration or shock
- Product is in direct contact with rain, water drops or sunlight

9 Disposal

- These products do not use nickel-cadmium batteries. Dispose of them as industrial waste.
- The optional module ME-0000BU-SS96 contains a lithium battery. Dispose of the battery in accordance with the municipal regulations.
- In EU member states, there is a separate collection system for used batteries. Dispose of the batteries properly at the local collection/recycling center. The following symbol is printed on the package of ME-0000BU-SS96.



This symbol is applicable only in EU member states. The symbol is designated in Article 20 "Information for end-users" and Annex II of the new European Directive on batteries (2006/66/EC).

The above symbol indicates that the batteries must be disposed of after separation from general waste.

CAUTION

- The optional module ME-0000BU-SS96 contains a lithium battery. Therefore, if it is thrown into the fire, it may generate heat, rupture or ignite. Dispose of the lithium battery in accordance with the municipal regulations.

10 Warranty Period

The warranty period for the products in this catalog expires one year from the date of purchase or one year and six months after the date of manufacture; whichever is earliest. Even during the warranty period, the warranty shall not apply to malfunctions attributable to intentional negligence or erroneous use by the customer, and the fee for any repair required as the result of such negligence shall be the liability of the customer.

Mitsubishi Electric shall not be liable for: Damage that cannot be attributed to Mitsubishi Electric; lost opportunity or earnings resulting from failure of a Mitsubishi Electric product; damage, secondary damage or compensation for an accident resulting from special circumstances regardless of whether or not the circumstances were foreseeable; or damage to products or other services for products not manufactured by Mitsubishi Electric.

11 Product Exchange Cycle

Although it depends on usage conditions, as a guide, it is recommended that the products listed in this catalog be renewed after 10 years.

● Trademarks

- MODBUS is a trademark of Schneider Electric USA Inc.
- Ethernet is a trademark of Fuji Xerox Co., Ltd.
- Other company and product names herein are trademarks or registered trademarks of their respective owners.
- In the text, trademark symbols such as "TM" and "®" may not be written.

(MEMO)

FONLEE
豐立自動控制器材有限公司
WWW.FONLEE.COM.TW

(MEMO)

FONLEE
豐立自動控制器材有限公司
WWW.FONLEE.COM.TW

ELECTRONIC MULTI-MEASURING INSTRUMENT

Service Network

Country/Region	Corporation Name	Address	Telephone
Australia	Mitsubishi Electric Australia Pty. Ltd.	348 Victoria Road, Rydalmere, N.S.W. 2116, Australia	+61-2-9684-7777
Bangladesh	PROGRESSIVE TRADING CORPORATION ELECTRO MECH AUTOMATION& ENGINEERING LTD.	HAQUE TOWER,2ND FLOOR,61011, JUBILEE ROAD, CHITTAGONG, BANGLADESH SHATABDI CENTER, 12TH FLOOR, 2-4, 292, INNER CIRCULAR ROAD, FAKIRA POOL, MOTIJHEEL, DHAKA-1000, BANGLADESH	+880-31-624307 +88-02-7192826
Belarus	Tekhnicon	Oktyabrskaya 19, Off. 705, BY-220030 Minsk, Belarus	+375 (0) 17 / 210 46 26
Belgium	Koning & Hartman B.V.	Woluweilaan 31, BE-1800 Vilvoorde, Belgium	+32 (0)2 / 2570240
Brazil	Mitsubishi Electric Do Brasil Comercio E Servicos Ltda.	Av. Adelfino Cardana, 293 -21 and - C. Bethaville, 06401-147, Barueri/SP - Brasil	+55-11-4689-3000
Cambodia	DHINIMEX CO.,LTD	H249, Si. Tea Phnom, Phnom Penh, Cambodia	+855-23-997-725
Chile	Rhona S.A.	Vta. Agua Santa 4211 Casilla 30-D (P.O. Box) Vina del Mar, Chile	+56-32-320-6000
	Mitsubishi Electric Automation (China) Ltd.	Mitsubishi Electric Automation Building, No.1386 Hongqiao Road, Shanghai,200336	+86-21-2322-3030
	Mitsubishi Electric Automation (China) Ltd. North China Branch	9/F, Office Tower1 Henderson Centre 18 Jiaquomennei Dajie DongCheng district BeiJing 100005	+86-10-6518-8830
	Mitsubishi Electric Automation (China) Ltd. NorthEast China Branch	Room 2302, President Building Tower C, No.69 Heping North Avenue, Heping District, Shenyang, 110003	+86-24-2259-8830
	Mitsubishi Electric Automation (China) Ltd. South China Branch	Room 2512-2516, Great China International Exchange Square, Jinlian Rd.S., Futian District, Shenzhen, 518034	+86-755-2399-8272
	Mitsubishi Electric Automation (China) Ltd. South China Branch	Room 1608, North Tower, The Hub Center, No.1068, Xing Gang East Road, Haizhu District, GuangZhou, China 510335	+86-20-8923-6730
	Mitsubishi Electric Automation (China) Ltd. SouthWest China Branch	1501,1502,1503,15F,Guang-hua Centre,Block C,NO.98 Guang Hua North 3th Road Chengdu,610000	+86-28-8446-8030
Colombia	Proelectric Representaciones S.A.	20F, Citytaza One, 1111 king's Road, Talkoo shing, Hong Kong	+57-4-4441284
Czech Republic	AUTOCONT CONTROL SYSTEMS S.R.O	Camera 42 # 75-367 Bod 109 Itagu Colombia	+420 595 691 150
Denmark	BEIJER ELECTRONICS A/S	LYKKEGARDSVEJ 17, DK-4000 ROSKILDE	+45 (0)46 75 76 66
Egypt	Cairo Electrical Group	9, Rostom St. Garden City P.O. Box 165-11516 Maglis El-Shaab,Cairo - Egypt	+20-2-27961337
France	Mitsubishi Electric Europe B.V.	25, Boulevard des Bouvels, F-92741 Nanterre Cedex	+33 (0) 1 55 68 55 68
Germany	Mitsubishi Electric-Pratz 1	Mitsubishi Electric-Pratz 1, 40882 Ratingen, Germany	+49 (0)202 4860
Greece	KALAMARAKIS - SAPOUNAS S.A.	IONIAS & NEROMILOU STR., CHAMOMILOS ACHARNES, ATHENS, 13678 Greece	+30-2102 406000
	UTECCO	5, MAVROGENOUS STR., 18542 PIRAEUS, Greece	+30-211-1206-900
Hungary	Mettrade Ltd.	Fertő utca 14, HU-1107 Budapest, Hungary	+36 (0)1-431-9726
India	Mitsubishi Electric India Private Limited	2nd Floor, Tower A&B, Cyber Greens, DLF Cyber City, DLF Phase-III, Gurgaon - 122 022 Haryana, India	+91-124-4630300
Indonesia	PT.Mitsubishi Electric Indonesia	Gedung Jaya 8th floor, J.L.MH. Thamrin No.12 Jakarta Pusat 10340, Indonesia	+62-21-3192-6461
	P.T. Sahabat Indonesia	P.O.Box 5045 Kawasan Industri Pergudangan, Jakarta, Indonesia	+62-(0)21-6610851-9
Ireland	Mitsubishi Electric Europe B.V.	Westgate Business Park, Ballymount, IRL-Dublin 24, Ireland	+353 (0)1-4198800
Israel	Gino Industries Ltd.	26, Ophir Street IL-32235 Haifa, Israel	+972 (0)4-867-0656
Italy	Mitsubishi Electric Europe B.V.	Viale Colsoni 7, I-20041 Agrate Brianza (MI), Italy	+39 039-60531
Kazakhstan	Kazpromavtomatika	Ul. Zhambyla 28, KAZ - 100017 Karaganda	+7 7212 510000
Korea	Mitsubishi Electric Automation Korea Co., Ltd	9F Gangseo Hangang xi-tower, 401 Yangcheon-ro, Gangseo-gu, Seoul 07528 Korea	+82-2-3660-9572
Laos	AROUNKIT CORPORATION IMPORT. EXPORT SOLE CO.,LTD	SAPHANOU VILLAGE, SAYSETHA DISTRICT, VIENTIANE CAPITAL, LAOS	+856-20-415899
Lebanon	Comptoir d'Electricite Generale-Liban	Cebaco Center - Block A Autostrade Dora, P.O. Box 11-2597 Beirut - Lebanon	+961-1-240445
Lithuania	Rifas UAB	Tinklu 29A, LT-5300 Panevezys, Lithuania	+370 (0)45-582-728
Malaysia	Mitric Sdn Bhd	No. 5, Jalan Pemberita U1/49, Temasya Industrial Park, Glenmarie 40150 Shah Alam,Selangor, Malaysia	+603-5569-3748
Malta	ALFATRADE LTD	99 PAOLA HILL, PAOLA PLA 1702, Malta	+356 (0)21-697-816
Marocco	SCHIELE MAROC	KM 7,2 NOUVILLE ROUTE DE RABAT AIN SEBAA, 20600 Casablanca, Marocco	+212 661 45 15 96
Mexico	Mitsubishi Electric Automation, Inc.	Mariano Escobedo 69, Col. Zona Industrial, Tlalneapantla, MEX - 54030 - MX	+52-3667-7500
Myanmar	Peace Myanmar Electric Co.,Ltd.	NO137/139 Botahtaung Pagoda Road, Botahtaung Tower Ship 11161, Yangon, Myanmar	+95-(0)1-202589
Nepal	Watt&Volt House	KHA 2-65, Volt House Dillibazar Post Box-2108, Kathmandu, Nepal	+977-1-4411330
Netherlands	Imtech Marine & Offshore B.V.	Suisjesdijk 155, NL-3087 AG Rotterdam, Netherlands	+31 (0)10-487-19 11
North America	Mitsubishi Electric Automation, Inc.	500 Corporate Woods Parkway, Vernon Hills, IL 60061 USA	+847-478-2100
Norway	Scanelec AS	Leivikasen 43B, NO-5179 Godvik, Norway	+47 (0)55-056000
Middle East Arab Countries & Cyprus	Comptoir d'Electricite Generale-International-S.A.L.	Cebaco Center - Block A Autostrade Dora P.O. Box 11-1314 Beirut - Lebanon	+961-1-240430
	Prince Electric Co.	2/P GULBERG II, LAHORE, 54800, PAKISTAN	+92-42-575232, 5753373
	AL-KAMAL GROUP	OFFICE NO.7&8, 1ST FLOOR, BARKAT ALI KHAN CENTER, 101, CIRCULAR ROAD, LAHORE, PAKISTAN	+92-42-37631632
Pakistan			
Philippines	Edison Electric Integrated, Inc.	24th Fl. Galleria Corporate Center, Edsa Cr. Ortigas Ave., Quezon City Metro Manila, Philippines	+63-(0)2-634-8691
Poland	Mitsubishi Electric Europe B.V. Polish Branch	Krakowska 50, 32-083 Balice, Poland	+48 (0) 12 630 47 00
Republic of Moldova	Intehsis SRL	bld. Traian 23/1, MD-2060 Kishinev, Moldova	+373 (0)22-66-4242
Romania	Sirius Trading & Services SRL	RO-060841 Bucuresti, Sector 6 Aleea Lacul Morii Nr. 3	+40-(0)21-430-40-06
Russia	Mitsubishi Electric Europe B.V. Moscow Branch	52, bld. 3 Kosmodamianskaya Nab. 115054, Moscow, Russia	+7 495 721-2070
Saudi Arabia	Center of Electrical Goods	Al-Shuwayer St. Side way of Salahuddin Al-Ayoubi St. P.O. Box 15955 Riyadh 11454 - Saudi Arabia	+966-1-4770149
Singapore	Mitsubishi Electric Asia Pte. Ltd.	307 Alexandra Road, Mitsubishi Electric Building, Singapore 159943	+65-6475-2308
Slovakia	PROCONT, Presov	Kupelna 1/ SK - 08001 Presov, Slovakia	+421 (0)51 - 7580 611
	SIMAP	Jana Derku 1671, SK - 91101 Trenčin, Slovakia	+ 421 (0)32 743 04 72
Slovenia	Inea RBT d.o.o.	Stegne 11, SI-1000 Ljubljana, Slovenia	+386 (0)1-513-8116
South Africa	CBI-electric low voltage	101 Tru Digital Park Office, 5th Floor, Sakumvit Road, Bangchak, Phra Khanong, Bangkok, 10250 TRUE DIGITAL PARK SUKHUMVIT 101	+27-(0)11-9282000
Spain	Mitsubishi Electric Europe B.V. Spanish Branch	Carretera de Rubi 76-80, E-08190 Sant Cugat del Valles (Barcelona), Spain	+34 (0)93-565-3131
Sweden	Euro Energy Components AB	Järnvägsгатan 36, S-434 24 Kungälv, Sweden	+46 (0)300-690040
Switzerland	TriElec AG	Muehlentalstrasse 136, CH-8201 Schaffhausen	+41-(0)52-6258425
Taiwan	Setsuyo Enterprise Co., Ltd	5th Fl., No.105, Wu Kung 3rd, Wu-Ku Hsiang, Taipei, Taiwan, R.O.C.	+886-(0)2-2298-8889
Thailand	United Trading & Import Co., Ltd.	77/12 Bamrungmuang Road, Kleng Mahanak Pomprab Bangkok Thailand	+66-223-220-3
	MITSUBISHI ELECTRIC FACTORY AUTOMATION (THAILAND) CO., LTD.	101 Tru Digital Park Office, 5th Floor, Sakumvit Road, Bangchak, Phra Khanong, Bangkok, 10250 TRUE DIGITAL PARK SUKHUMVIT 101	+662-092-8600
Tunisia	MOTRA Electric	3, Résidence Imen, Avenue des Martyrs Mourouj III, 2074 - El Mourouj III Ben Arous, Tunisia	+216-71 474 599
Turkey	GTS	Bayraktar Bulvan Nutuk Sok. No.5, Posta Kutusu34384, TR-34775 Yukan Dudullu-Uemraniye, Istanbul, Turkey	+90 (0)216 526 3990
United Kingdom	Mitsubishi Electric Europe B.V.	Travelers Lane, UK-Hatfield, Herts. AL10 8XB, United Kingdom	+44 (0)1707-276100
Uruguay	Fierro Vignoli S.A.	Avda. Uruguay 1274 Montevideo Uruguay	+598-2-902-0808
Venezuela	Adesco S.A.	Calles 7 La Urbina Edificio Los Robles Locales C y D Planta Baja, Caracas - Venezuela	+58-212-241-9952
	Mitsubishi Electric Vietnam Co.,Ltd. Head Office	Unit01-04, 10th Floor, Vincom Center, 72 Le Thanh Ton Street, District 1, Ho Chi Minh City, Vietnam	+84-8-3910-5945
	Mitsubishi Electric Vietnam Co.,Ltd. Hanoi Branch	24th-Floor, Handico Tower, Pham Hung Road, Me Tri Ha Ward, Nam Tu Liem District, Hanoi, Vietnam	+84-24-3937-8075

Safety Tips: Be sure to read the instruction manual fully before using this product.

Precautions Before Use

- Please consult with a Mitsubishi Electric representative when considering the application of products presented in this catalogue with machinery or systems designed for specialized use such as nuclear power, electrical power, aerospace/outer space, medical, or passenger transportation vehicles.
- Mitsubishi Electric Corporation shall not be liable, to the customer or equipment user, for:
 - 1) Any damage found not to be attributable to a Mitsubishi Electric product.
 - 2) The loss of opportunity or profits for the customer or user caused by any fault in a Mitsubishi Electric product.
 - 3) Damage, secondary damage or accident compensation resulting from special factors regardless of whether or not such factors could be predicted by Mitsubishi Electric.
 - 4) Damage to products of other companies and/or guarantees relating to other services.



for a greener tomorrow

Eco Changes is the Mitsubishi Electric Group's environmental statement, and expresses the Group's stance on environmental management. Through a wide range of businesses, we are helping contribute to the realization of a sustainable society.



MITSUBISHI ELECTRIC CORPORATION

HEAD OFFICE: TOKYO BUILDING, 2-7-3, MARUNOUCHI, CHIYODA-KU, TOKYO 100-8310, JAPAN