

## 2-way pilot operated diaphragm solenoid valves normally open, energized to close



### Features:

1. Suitable for air, inert gases, vacuum (10 TORR), water, kerosene oil, and oil (Below 50 cst).
2. Pilot operated, pressure range from 0.3kg\*f/cm<sup>2</sup> to 10kg\*f/cm<sup>2</sup>.
3. Can be mounted in vertical and horizontal position.

Model	Connection	Orifice (mm)	Cv Value	Operating pressure (kg*f/cm <sup>2</sup> )		Max. Media Temp.	Power Consumption VA
				Air, Water Inert gases	Oil (Below 50cst)		
MD-10C-M17	PT 3/8"	16	3.7	0.1-10	0.1-7	90°C	26
MD-15C(SCS <sup>13</sup> <sub>14</sub> )-M17	PT 1/2"	16	3.7				
MD-20C(SCS <sup>13</sup> <sub>14</sub> )-M17	PT 3/4"	23	6.3				
MD-25C(SCS <sup>13</sup> <sub>14</sub> )-M17	PT 1"	28	8				
MD-32C(SCS <sup>13</sup> <sub>14</sub> )-M17	PT 1 1/4"	32	13				
MD-40C(SCS <sup>13</sup> <sub>14</sub> )-M17	PT 1 1/2"	40	20.3				
MD-50C(SCS <sup>13</sup> <sub>14</sub> )-M17	PT 2"	50	32				

\* NPT on request. \* (SCS13) Valve bonnet, Valve body material SCS13.  
(SCS14) Valve bonnet, Valve body material SCS14.

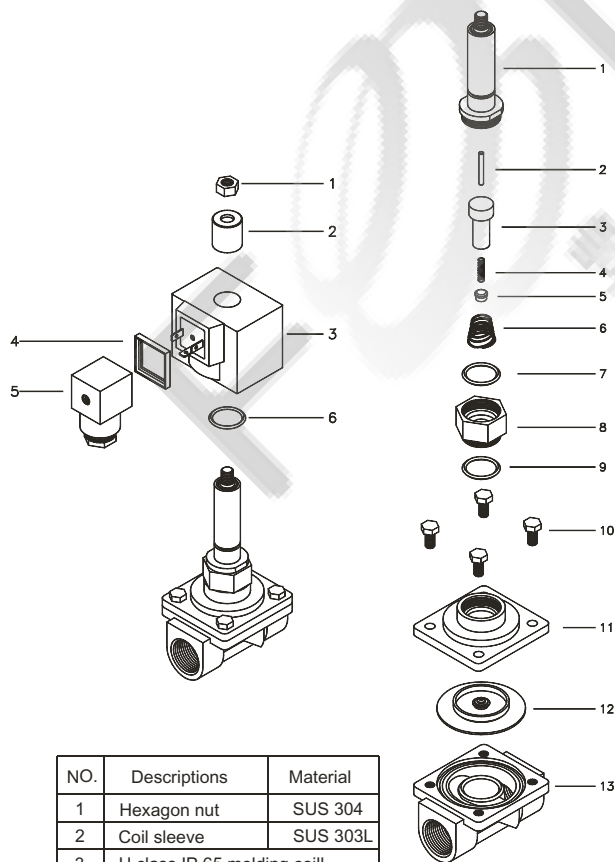
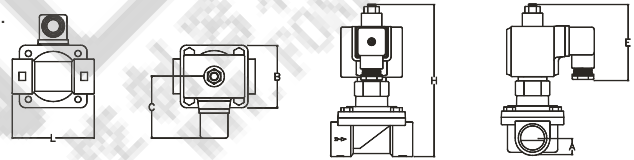

NO.	Descriptions	Material
1	Hexagon nut	SUS 304
2	Coil sleeve	SUS 303L
3	H class IP 65 molding coil	
4	Terminal box packing pad	
5	Terminal box	
6	O ring	NBR

Model	Connection	L (mm)	H (mm)	A (mm)	B (mm)	C (mm)	E (mm)
MD-10C -M17	PT 3/8"	70	147	15	52	65	73
MD-15C(SCS <sup>13</sup> <sub>14</sub> )-M17	PT 1/2"	70	147	15	52		
MD-20C(SCS <sup>13</sup> <sub>14</sub> )-M17	PT 3/4"	80	157	17.5	62		
MD-25C(SCS <sup>13</sup> <sub>14</sub> )-M17	PT 1"	90	167	23	72		
MD-32C(SCS <sup>13</sup> <sub>14</sub> )-M17	PT 1 1/4"	120	149	26	83		
MD-40C(SCS <sup>13</sup> <sub>14</sub> )-M17	PT 1 1/2"	136	159	32	97		
MD-50C(SCS <sup>13</sup> <sub>14</sub> )-M17	PT 2"	160	169	37	112		

NO.	Descriptions	Material
1	Plunger tube unit	SUS 304, KM-31
2	Needle stem	SUS 303L
3	Seat sleeve	SUS 303L
4	Plunger spring	SUS 304
5	Plunger seat	H NBR
6	Spring	SUS 304
7	O ring	NBR
8	Hexagon bushing nut	SUS 303L
9	O ring	NBR
10	Hexagon bolt	SUS 304
11	Valve bonnet	3/8" ~1" (C3771BE) 1-1/4" ~2"(BC 6) 1/2" ~2"(SCS13/SCS14)
12	Diaphragm a'ssy	SUS304, BSBF(SUS304) NBR(EPDM)(VITON)
13	Valve body	3/8" ~1" (C3771BE) 1-1/4" ~2"(BC 6) 1/2" ~2"(SCS13/SCS14)