



## Epoxy Bus Bushing Board Epoxy穿盤絕緣板

巧於創意 · 力臻價值

### ■ 功能 (Functions):

1. 方便盤間母線(銅排)之配線作業  
It is convenient to wiring (copper bar) between panels.
2. 盤間故障災害之隔離  
Insulated fault or disasters between panels.
3. 避免銅排間絕緣破壞時電弧沿銅排游移擴散  
To prevent arc happen and expanded along the copper bus when if the copper bus space has been insulated breakdown.

### ■ 特點 (Features):

1. Epoxy材質，堅固耐用，易保養  
Epoxy material, durable, easy to maintain.
2. 模具灌注一次成型，美觀，尺寸準確  
Integrally molded, beautiful appearance, accurate dimensions.
3. 水平與垂直銅排配線二種型式  
Two types for copper bus wiring:  
Horizontal and Vertical.
4. 不吸濕，表面絕緣良好，不助燃  
Non hygroscopic, high-level surface insulated, self-extinguished.

### ■ 電氣特性(Electrical Characteristics):

1. 額定系統電壓：24K V  
Rated System Voltage: 24KV
2. 耐壓：50KV/1M  
Withstand Voltage: 50KV/1M
3. 衝擊電壓：125KV  
Impulse Voltages: 125KV
4. 概重：17KG  
Approximately Weight: 17KG



**CIC 巧力互業股份有限公司**  
CHALLENGE INDUSTRIAL CO., LTD.

Tel : 886-2-2788-3368 Fax : 886-2-2788-3319  
11570 台北市南港區南港路三段80巷46號1樓  
E-mail : cic\_ltd@seed.net.tw  
免付費電話 : 0800-251-176

■ 外型尺寸 Dimention (mm)

1. Type : CEBB-20V131 垂直安装式  
(Vetical Bus Mountiong)

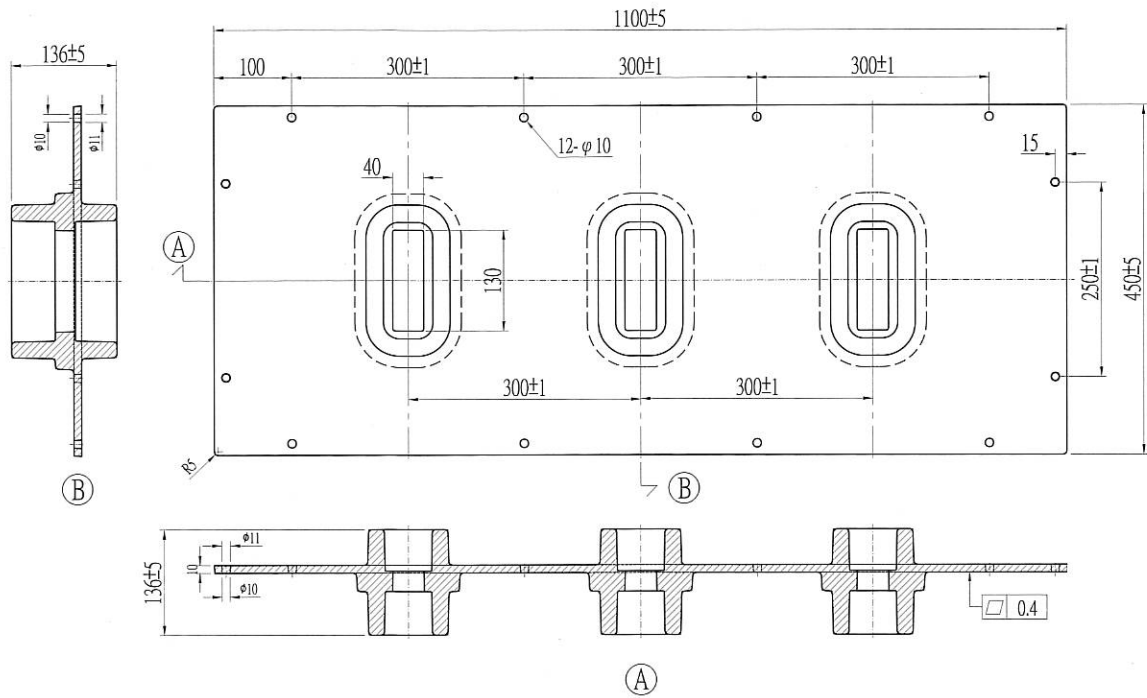

2. Type : CEBB-20H131水平安装式  
(Horizontal Bus Mountiong)

